

**Knjiga
standarda
za korištenje
jedinstvenog
vizualnog
identiteta
zaštite prirode
u Republici
Hrvatskoj**

4	jedinstveni vizualni identitet	36	vertikalni odnos znak-logotip HR
6	osnovni grafički standardi	37	dimenzije pozitiv
7	verzije znakova i odnosa znak-logotip	38	dimenzije negativ
8	znak	39	minimalni zaštitni prostor
9	dimenzije	40	apliciranje - akromatske kontinuirane podloge
10	minimalni zaštitni prostor	41	apliciranje - kromatske kontinuirane podloge
11	apliciranje - akromatske kontinuirane podloge	42	apliciranje - diskontinuirane podloge
12	apliciranje - kromatske kontinuirane podloge	43	zabrane
13	apliciranje - diskontinuirane podloge	44	vertikalni odnos znak-logotip ENG
14	zabrane	45	dimenzije pozitiv
15	horizontalni odnos znak-logotip HR	46	dimenzije negativ
16	dimenzije	47	minimalni zaštitni prostor
17	minimalni zaštitni prostor	48	apliciranje - akromatske kontinuirane podloge
18	apliciranje - akromatske kontinuirane podloge	49	apliciranje - kromatske kontinuirane podloge
19	apliciranje - kromatske kontinuirane podloge	50	apliciranje - diskontinuirane podloge
20	apliciranje - diskontinuirane podloge	51	zabrane
21	zabrane	52	vertikalni odnos znak-logotip HR/ENG
22	horizontalni odnos znak-logotip ENG	53	dimenzije pozitiv
23	dimenzije	54	dimenzije negativ
24	minimalni zaštitni prostor	55	minimalni zaštitni prostor
25	apliciranje - akromatske kontinuirane podloge	56	apliciranje - akromatske kontinuirane podloge
26	apliciranje - kromatske kontinuirane podloge	57	apliciranje - kromatske kontinuirane podloge
27	apliciranje - diskontinuirane podloge	58	apliciranje - diskontinuirane podloge
28	zabrane	59	zabrane
29	horizontalni odnos znak-logotip HR/ENG	60	tipografija vizualnog identiteta
30	dimenzije	61	boja vizualnog ideniteta
31	minimalni zaštitni prostor	62	odnosi znaka zaštite prirode i znaka pojednog parka
32	apliciranje - akromatske kontinuirane podloge	63	horizontalan odnos znakova
33	apliciranje - kromatske kontinuirane podloge	64	horizontalan odnos
34	apliciranje - diskontinuirane podloge	66	vertikaln odnos
35	zabrane		

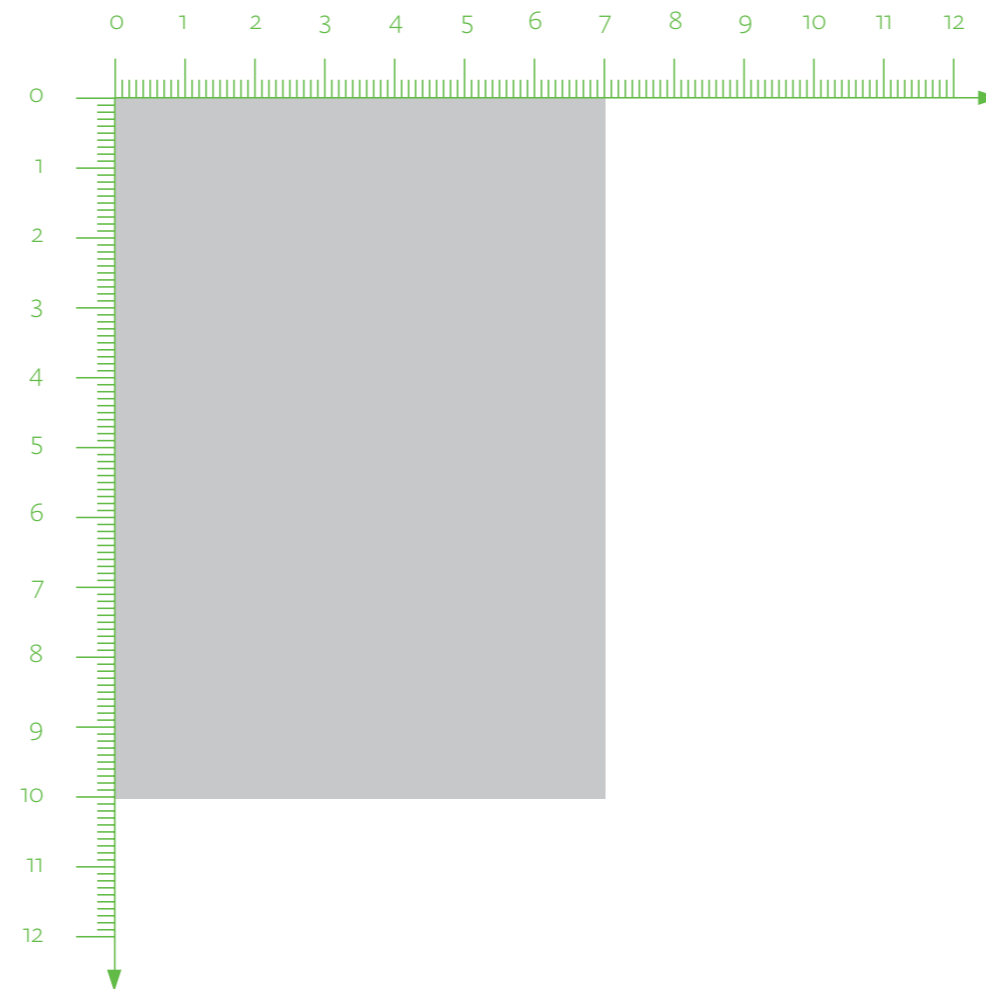

Kotiranje

Svi predmeti koji se nalaze u knjizi standarda iskotirani su u koordinatnom sustavu sličnom onom koji koriste profesionalni vektorski programi. Sve mjere su izražene u milimetrima. Predmeti su iskotirani tako da im se gornji lijevi kut uvijek nalazi u ishodištu koordinatnog sustava.

Tipografija

Tipografija upotrebljena na predmetu prikazanom na pojedinoj stranici definirana je u tekstualnom dijelu stranice. Definirana je svojim imenom, rezom, te veličinom i preredom. Veličina i prered izraženi su u točkama i označavaju se ovako:

 mjerna jedinica

10/12 pt

 veličina proreda

 veličina slovnog znaka

Osnovni grafički standardi

U ovoj knjizi standarda predstavljen je sustav apliciranja elemenata jedinstvenog vizualnog identiteta.

Osnovni elementi vizualnog identiteta su: znak, logotip, boja i tipografija te logika apliciranja tih elemenata.

→
ZNAK ZAŠTITE
PRIRODE



znak

logotip

→
LOGOTIP PARKOVI
HRVATSKE



PARKOVI Parks
of Croatia
HRVATSKE

boje

tipografija

Jedinstveni vizualni identitet

Potreba za novim jedinstvenim vizualnim identitetom zaštite prirode proizašla je iz strategije zajedničkog nastupanja u medijima. Novim sustavom vizualne komunikacije promidžba jednog parka ujedno je i pomidžba svih drugih parkova.

Jedinstveni vizualni identitet osmišljen je i dizajniran tako da svaki pojedinačni vizualni identitet funkcionira zasebno, ali su svi izvedeni istim grafičkim jezikom. Taj novouspostavljeni grafički jezik obuhvatio je identitete 19 parkova i krovni znak zaštite prirode. Znakovi parkova figurativni su motivi koji predstavljaju najveće vrijednosti pojedinog parka.

Novim jedinstvenim vizualnim identitetom parkovi u Hrvatskoj jasno vizualno komuniciraju da su svi dio sustava zaštite prirode.

Iste boje i tipografija, kao glavni elementi vizualnog identiteta, koriste se i na sustavu signalizacije i interpretacije na otvorenom.



PARKOVI HRVATSKE

Parks of Croatia



BIOKOVO

Park prirode
Nature Park



BRIJUNI

Nacionalni park
National Park



**KOPAČKI
RIT**

Park prirode
Nature Park



KORNATI

Nacionalni park
National Park



KRKA

Nacionalni park
National Park



**LASTOVSKO
OTOČJE**

Park prirode
Nature Park



**LONJSKO
POLJE**

Park prirode
Nature Park



MEDVEDNICA

Park prirode
Nature Park



MLJET

Nacionalni park
National Park



PAKLENICA

Nacionalni park
National Park



PAPUK

Park prirode
Nature Park



**PLITVIČKA
JEZERA**

Nacionalni park
National Park



RISNJAK

Nacionalni park
National Park



**SJEVERNI
VELEBIT**

Nacionalni park
National Park



TELAŠĆICA

Park prirode
Nature Park



UČKA

Park prirode
Nature Park



VELEBIT

Park prirode
Nature Park



**VRANSKO
JEZERO**

Park prirode
Nature Park



**ŽUMBERAK
SAMOBORSKO
GORJE**

Park prirode
Nature Park

Osnovni grafički standardi

Verzije znakova i odnosa znak logotip

U ovoj knjizi standarda definirani su odnosi znaka zaštite prirode i logotip Parkovi Hrvatske na hrvatskom jeziku, na engleskom jeziku i dvojezični, kao i horizontalni i vertikalni odnosi znaka i logotipa.



↑
AKVAREL ZNAK NEGATIV



↑
KOLOR ZNAK NEGATIV



↑
CRNO-BIJELI ZNAK NEGATIV



↑
HORIZONTALNI AKVAREL
ZNAK-LOGOTIP NEGATIV HR



↑
HORIZONTALNI KOLOR
ZNAK-LOGOTIP NEGATIV HR



↑
HORIZONTALNI CRNO-BIJELI
ZNAK-LOGOTIP NEGATIV HR



↑
HORIZONTALNI AKVAREL
ZNAK-LOGOTIP NEGATIV ENG



↑
HORIZONTALNI KOLOR
ZNAK-LOGOTIP NEGATIV ENG



↑
HORIZONTALNI CRNO-BIJELI
ZNAK-LOGOTIP NEGATIV ENG



↑
HORIZONTALNI AKVAREL
ZNAK-LOGOTIP NEGATIV HR/ENG



↑
HORIZONTALNI KOLOR
ZNAK-LOGOTIP NEGATIV HR/ENG



↑
HORIZONTALNI CRNO-BIJELI
ZNAK-LOGOTIP NEGATIV HR/ENG



↑
VERTIKALNI AKVAREL
ZNAK-LOGOTIP NEGATIV HR



↑
VERTIKALNI KOLOR
ZNAK-LOGOTIP NEGATIV HR



↑
VERTIKALNI CRNO-BIJELI
ZNAK-LOGOTIP NEGATIV HR



↑
VERTIKALNI AKVAREL
ZNAK-LOGOTIP NEGATIV ENG



↑
VERTIKALNI KOLOR
ZNAK-LOGOTIP NEGATIV ENG



↑
VERTIKALNI CRNO-BIJELI
ZNAK-LOGOTIP NEGATIV ENG



↑
VERTIKALNI AKVAREL
ZNAK-LOGOTIP NEGATIV HR/ENG



↑
VERTIKALNI KOLOR
ZNAK-LOGOTIP NEGATIV HR/ENG



↑
VERTIKALNI CRNO-BIJELI
ZNAK-LOGOTIP NEGATIV HR/ENG



↑
AKVAREL ZNAK POZITIV



↑
KOLOR ZNAK POZITIV



↑
CRNO-BIJELI ZNAK POZITIV



↑
HORIZONTALNI AKVAREL
ZNAK-LOGOTIP POZITIV HR



↑
HORIZONTALNI KOLOR
ZNAK-LOGOTIP POZITIV HR



↑
HORIZONTALNI CRNO-BIJELI
ZNAK-LOGOTIP POZITIV HR



↑
HORIZONTALNI AKVAREL
ZNAK-LOGOTIP POZITIV ENG



↑
HORIZONTALNI KOLOR
ZNAK-LOGOTIP POZITIV ENG



↑
HORIZONTALNI CRNO-BIJELI
ZNAK-LOGOTIP POZITIV ENG



↑
HORIZONTALNI AKVAREL
ZNAK-LOGOTIP POZITIV HR/ENG



↑
HORIZONTALNI KOLOR
ZNAK-LOGOTIP POZITIV HR/ENG



↑
HORIZONTALNI CRNO-BIJELI
ZNAK-LOGOTIP POZITIV HR/ENG



↑
VERTIKALNI AKVAREL
ZNAK-LOGOTIP POZITIV HR



↑
VERTIKALNI KOLOR
ZNAK-LOGOTIP POZITIV HR



↑
VERTIKALNI CRNO-BIJELI
ZNAK-LOGOTIP POZITIV HR



↑
VERTIKALNI AKVAREL
ZNAK-LOGOTIP POZITIV ENG



↑
VERTIKALNI KOLOR
ZNAK-LOGOTIP POZITIV ENG



↑
VERTIKALNI CRNO-BIJELI
ZNAK-LOGOTIP POZITIV ENG



↑
VERTIKALNI AKVAREL
ZNAK-LOGOTIP POZITIV HR/ENG



↑
VERTIKALNI KOLOR
ZNAK-LOGOTIP POZITIV HR/ENG



↑
VERTIKALNI CRNO-BIJELI
ZNAK-LOGOTIP POZITIV HR/ENG

Znak

POZITIV

AKVAREL ZNAK

'Akvarel znak' primarni je znak i preporuča se njegovo korištenje gdje god tehnika reprodukcije i sam dizajn to dopuštaju.

KOLOR ZNAK

'Kolor znak' sekundarni je znak. Upotrebljava se kada tehnika reprodukcije ne dopušta korištenje 'akvarel znaka'. (npr. sitotisak, oslikavanje, tampon tisak, štik, katiranje itd.)

CRNO-BIJELI ZNAK

'Crno-bijeli znak' tercijarni je znak. Upotrebljava se isključivo u situacijama kada je nemoguća kolor reprodukcija ili dizajn zahtjeva monokromatski znak. (npr. gravura, žig itd.)



↑
KOLOR ZNAK



↑
AKVAREL ZNAK



↑
CRNO-BIJELI ZNAK



↓
KOLOR ZNAK



↓
AKVAREL ZNAK



↓
CRNO-BIJELI ZNAK

NEGATIV

AKVAREL ZNAK

'Akvarel znak' primarni je znak i preporuča se njegovo korištenje gdje god tehnika reprodukcije i sam dizajn to dopuštaju.

KOLOR ZNAK

'Kolor znak' sekundarni je znak. Upotrebljava se kada tehnika reprodukcije ne dopušta korištenje 'akvarel znaka'. (npr. sitotisak, oslikavanje, tampon tisak, katiranje, štik itd.)

CRNO-BIJELI ZNAK

'Crno-bijeli znak' tercijarni je znak. Upotrebljava se isključivo u situacijama kada je nemoguća kolor reprodukcija ili dizajn zahtjeva monokromatski znak. (npr. gravura, katiranje itd.)

Dimenzije

Dimenzije znaka određuju se kako bi se stvorio kontinuitet veličina.

POZITIV

Minimalna veličina znaka je 6,7 × 6,7 mm. Znak se ne smije upotrebljavati manji od te dimenzije.

Za znak koji se upotrebljava u većim dimenzijama od ovdje ilustriranih vrijedi isto progresivno pravilo povećavanja - 500% x, 600% x, 700% x, 800% x, 900% x, 1000% x...

NEGATIV

Minimalna veličina znaka je 7,5 × 7,5 mm, odnosno 6,7 × 6,7 znaka crno-bijelog negativa.

Znak se ne smije upotrebljavati manji od tih dimenzija.

Za znak koji se upotrebljava u većim dimenzijama od ovdje ilustriranih vrijedi isto progresivno pravilo povećavanja - 500% x, 600% x, 700% x, 800% x, 900% x, 1000% x...

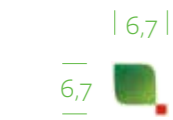

minimalna dimenzija = x
6,7×6,7 mm



150% x



200% x



300% x



400% x

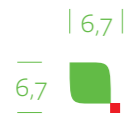

minimalna dimenzija = x
6,7×6,7 mm



150% x



200% x



300% x



400% x



minimalna dimenzija = x
6,7×6,7 mm



150% x



200% x



300% x



400% x



minimalna dimenzija = x
7,5×7,5 mm



150% x



200% x



300% x



400% x



minimalna dimenzija = x
7,5×7,5 mm



150% x



200% x



300% x



400% x



minimalna dimenzija = x
6,7×6,7 mm



150% x



200% x



300% x

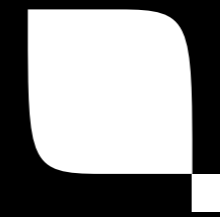

400% x

Minimalni zaštitni prostor

Minimalni zaštitni prostor znaka zaštite prirode je prostor oko znaka u kojem se ne smiju nalaziti drugi grafički elementi kako se ne bi narušio integritet samog znaka.

Minimalni zaštitni prostor određen je prema dimenziji a i prikazan je lijevo (točkasti pravokutnik).

Minimalni zaštitni prostor mijenja se proporcionalno sa dimenzijom samog znaka.

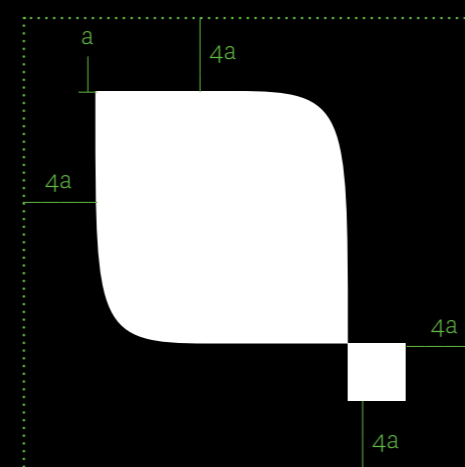
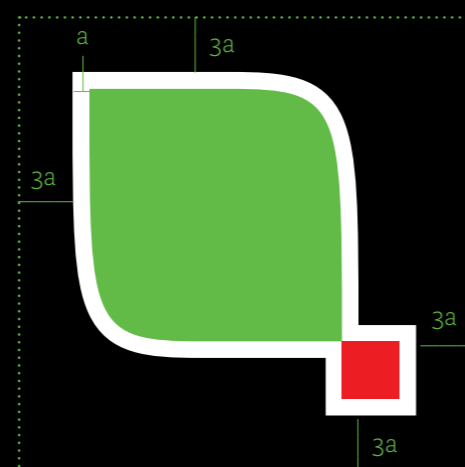
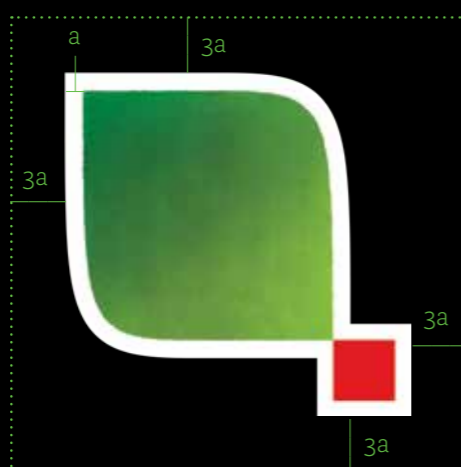
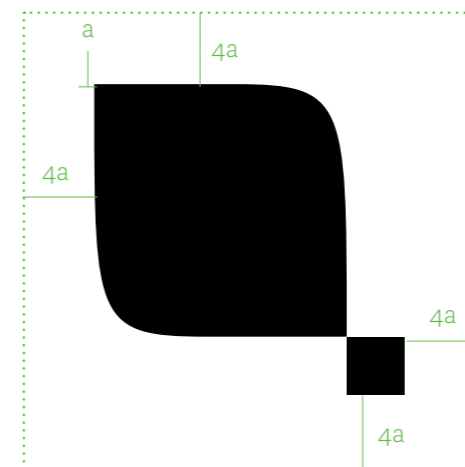
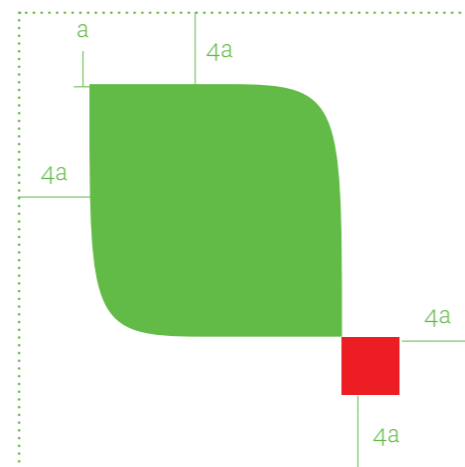
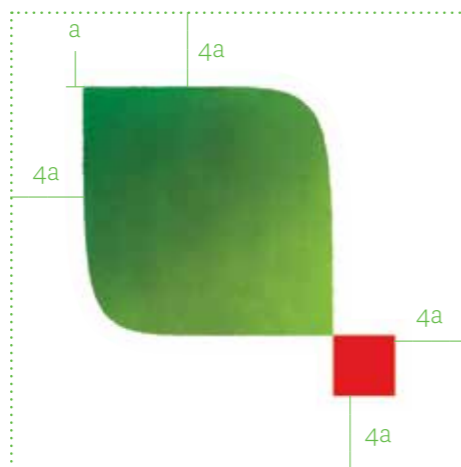

Apliciranje

AKROMATSKE KONTINUIRANE PODLOGE

Akromatske kontinuirane podloge su ravnomjerne podloge sivog spektra.

Akvarel i kolor znakovi se apliciraju u istom obliku na sve podloge.

Crno-bijeli znak se aplicira u negativu na sve akromatske kontinuirane podloge tamnije ili jednake 50% crne, a u pozitivu na sve akromatske kontinuirane podloge svjetlije od 50% crne.

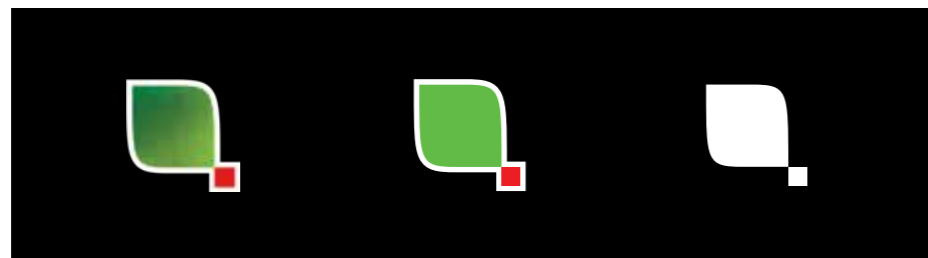

C: 0, M: 0, Y: 0, K: 100



C: 0, M: 0, Y: 0, K: 0

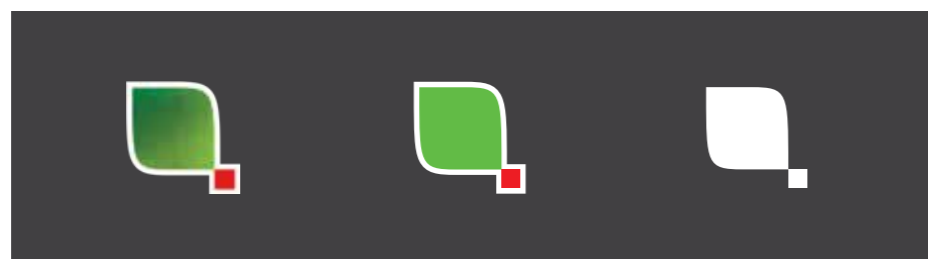

C: 0, M: 0, Y: 0, K: 90

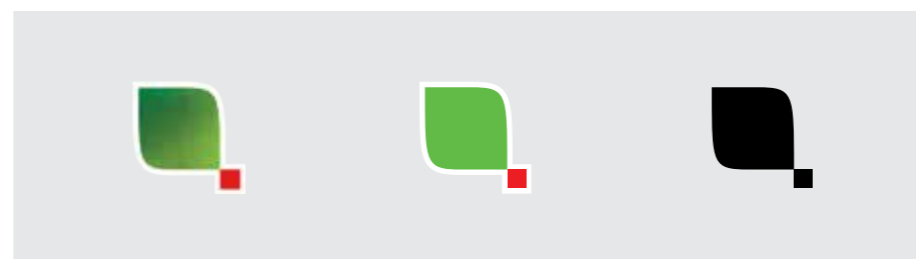

C: 0, M: 0, Y: 0, K: 10

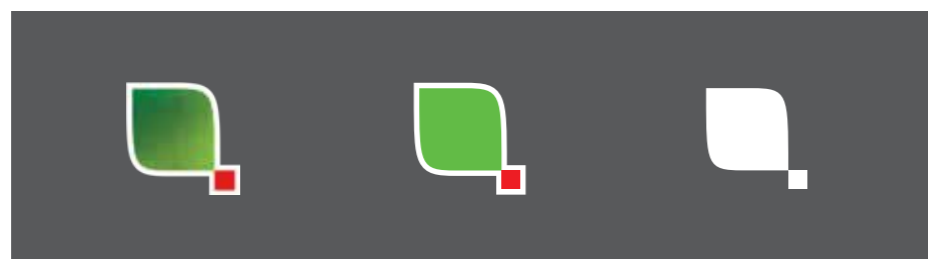

C: 0, M: 0, Y: 0, K: 80

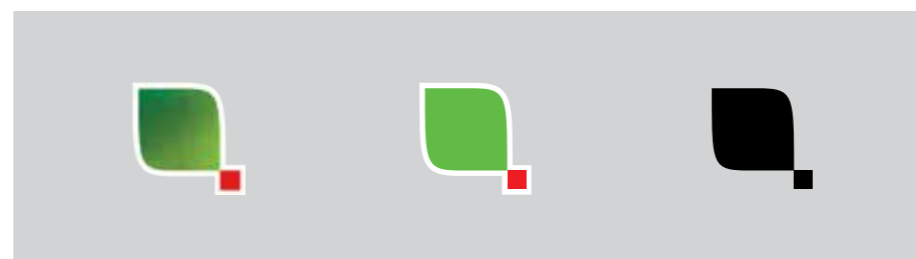

C: 0, M: 0, Y: 0, K: 20



C: 0, M: 0, Y: 0, K: 70

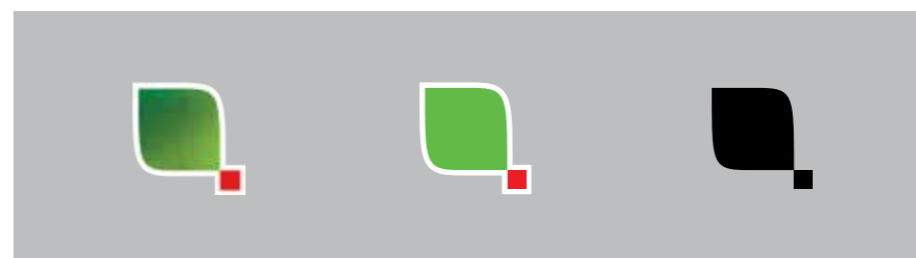

C: 0, M: 0, Y: 0, K: 30

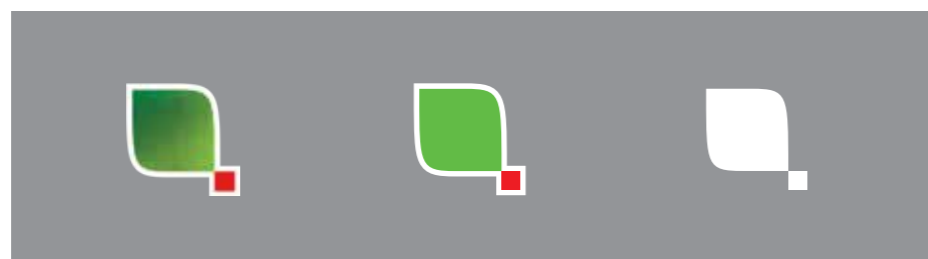

C: 0, M: 0, Y: 0, K: 50

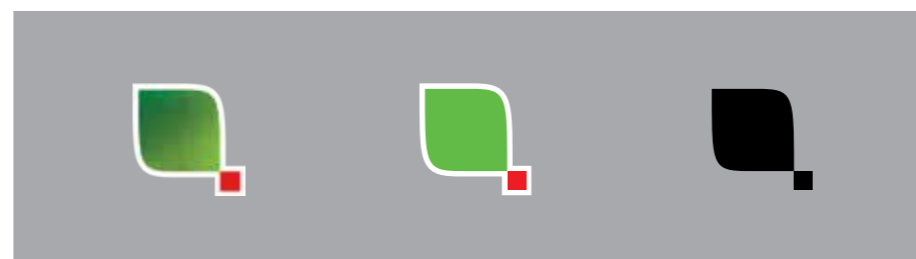

C: 0, M: 0, Y: 0, K: 40

Apliciranje

KROMATSKE KONTINUIRANE PODLOGE

Kromatske kontinuirane podloge su ravnomjerne obojane podloge.

Akvarelni i kolor znak se apliciraju u istom obliku na sve kromatske kontinuirane podloge.

Crno-bijeli znak se aplicira u negativu na sve kromatske kontinuirane podloge tamnije ili jednake 50% crne.

Crno-bijeli znak se aplicira u pozitivu na sve kromatske kontinuirane podloge svjetlije od 50% crne.

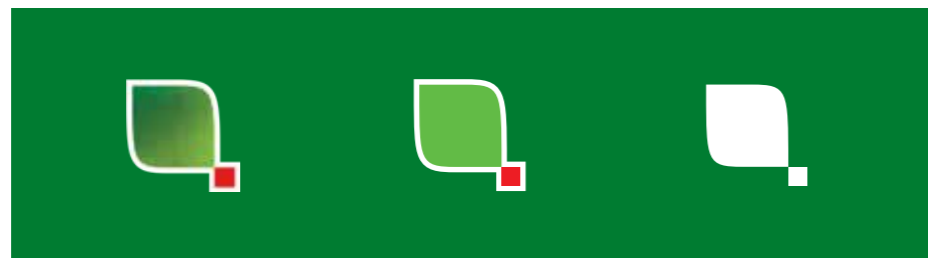

C: 100, M: 0, Y: 100, K: 20, grayscale ekvivalent 61%

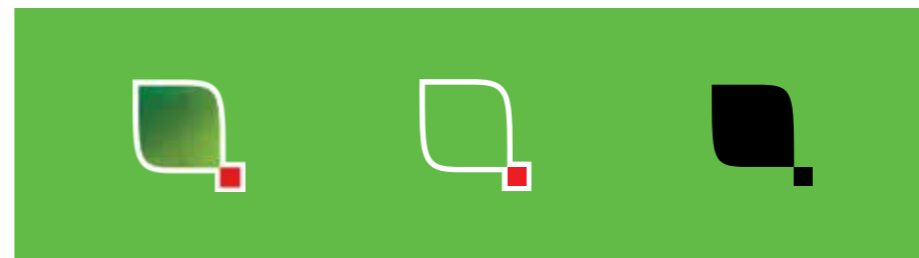

C: 100, M: 0, Y: 100, K: 20, grayscale ekvivalent 30%

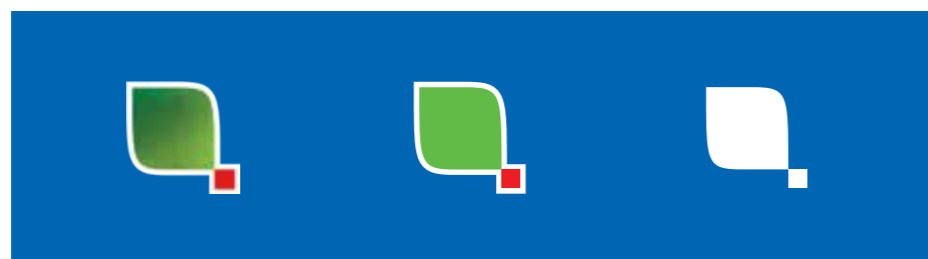

C: 100, M: 60, Y: 0, K: 0, grayscale ekvivalent 65%

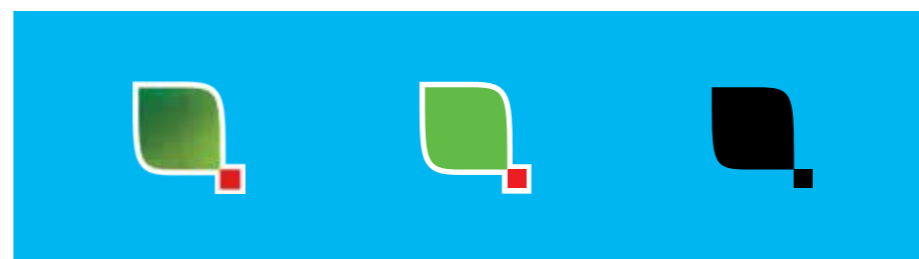

C: 85, M: 0, Y: 0, K: 0, grayscale ekvivalent 25%

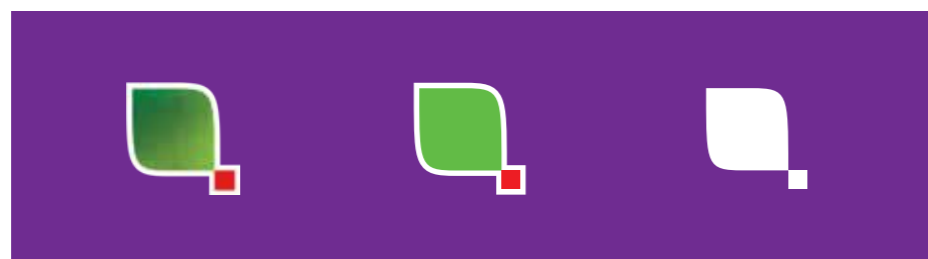

C: 70, M: 100, Y: 0, K: 0, grayscale ekvivalent 80%

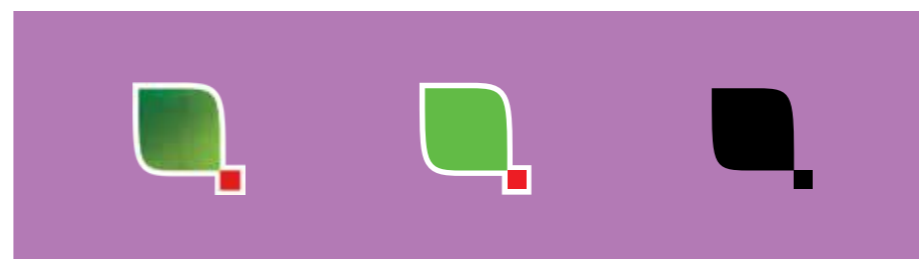

C: 30, M: 60, Y: 0, K: 0, grayscale ekvivalent 44%



C: 0, M: 100, Y: 100, K: 5, grayscale ekvivalent 50%



C: 0, M: 50, Y: 100, K: 0, grayscale ekvivalent 40%

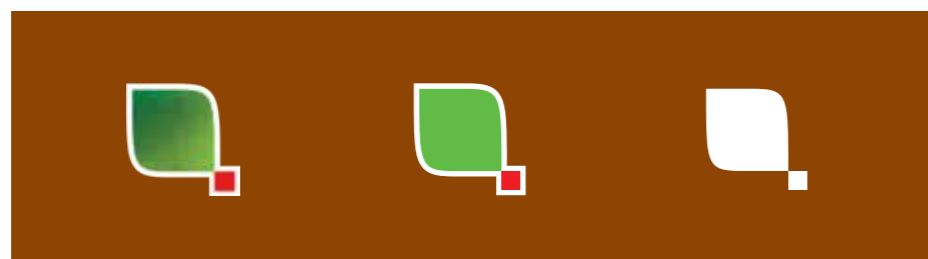

C: 0, M: 65, Y: 100, K: 50, grayscale ekvivalent 99%

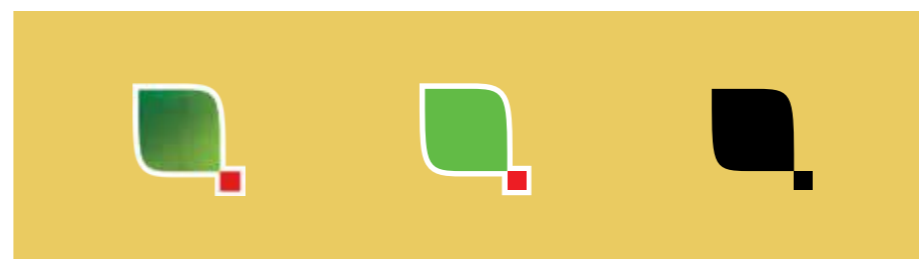

C: 0, M: 10, Y: 70, K: 10, grayscale ekvivalent 24%

Apliciranje

DISKONTINUIRANE PODLOGE

Diskontinuirana podloga je fotografska ili grafička podloga koja nije jednobojna.

Akvarelni i kolor znak se apliciraju u istom obliku na sve diskontinuirane podloge.

Crno-bijeli znak se aplicira u negativu na sve diskontinuirane podloge tamnije ili jednake 50% crne.

Crno-bijeli znak se aplicira u pozitivu na sve diskontinuirane podloge svjetlije od 50% crne.

Treba izbjegavati aplikaciju crno-bijelog znaka na diskontinuiranu podlogu koja je toliko heterogena da znak postaje nečitak.

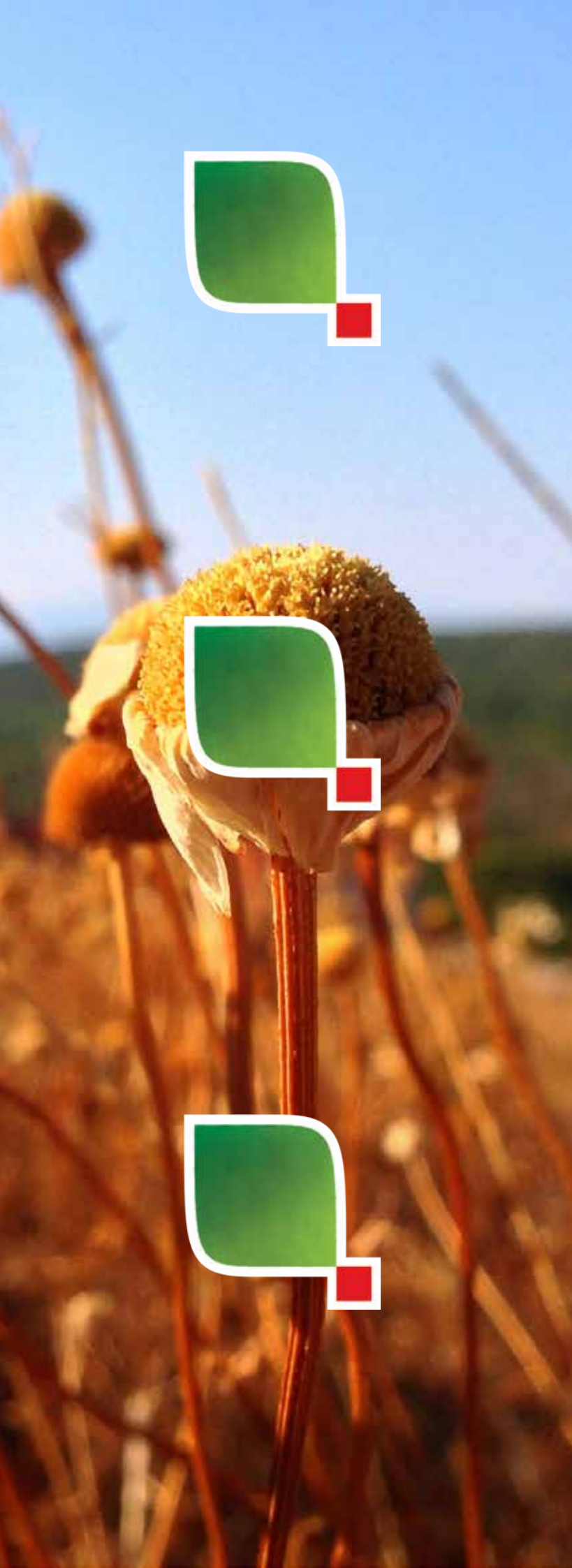

Zabrane

ZABRANJENE APLIKACIJE I MANIPULACIJE

Znak zaštite prirode se nikada ne smije deformirati (sužavati, izduživati, skraćivati, rotirati...). Oblik znaka strogo je propisan, te se svako njegovo narušavanje smatra deformacijom znaka.

Dozvoljena apliciranja znaka na razne pozadine ovise o njegovoj čitkosti i ne-narušavanju vizualne komunikativnosti.

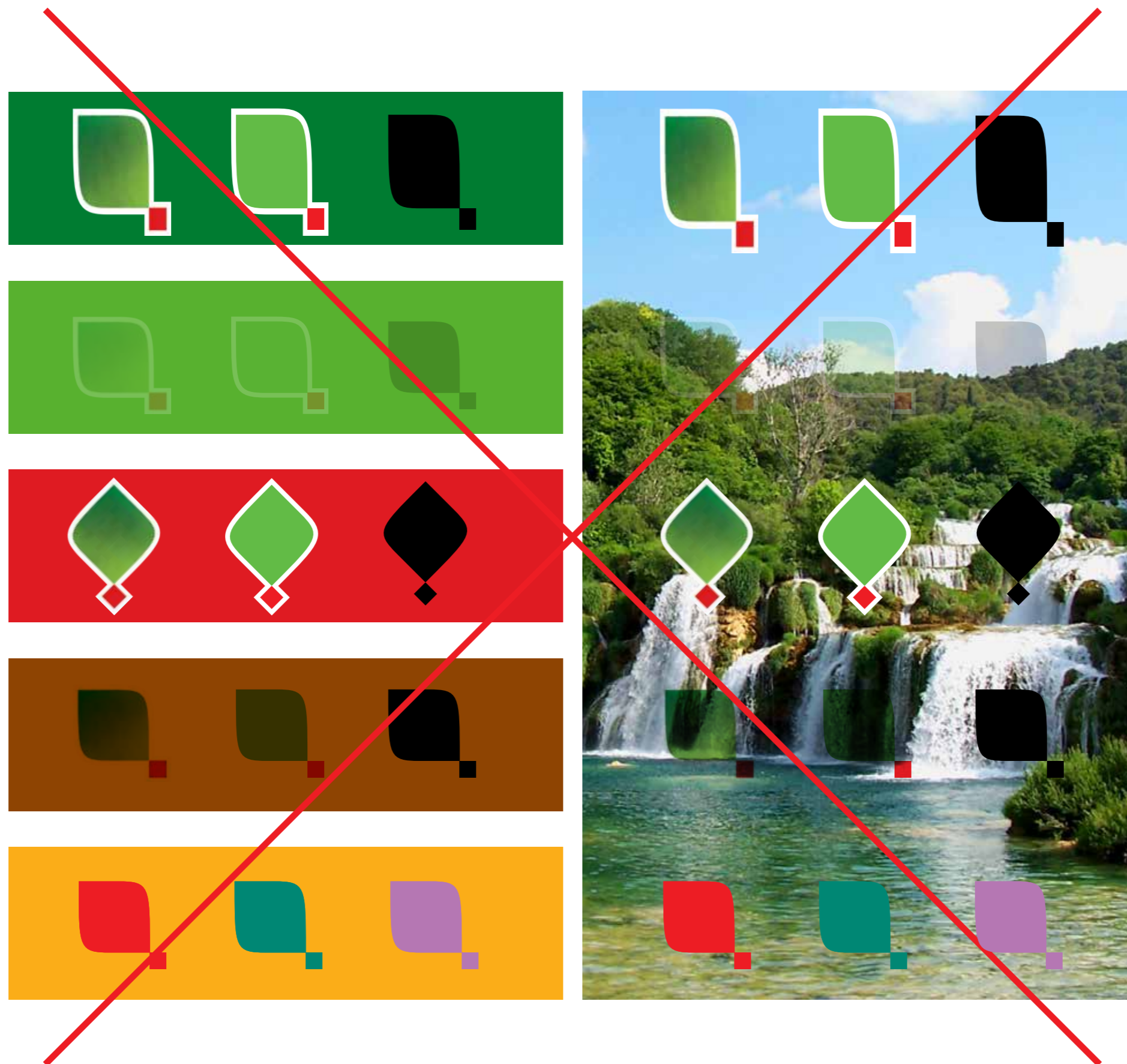

Horizontalni odnosi

NEGATIV

AKVAREL ZNAK-LOGOTIP HORIZONTALNI
'Akvel znak-logotip horizontalni' primarni je odnos znak-logotip i preporuča se njegovo korištenje gdje god tehnika reprodukcije i sam dizajn to dopuštaju.

KOLOR ZNAK-LOGOTIP HORIZONTALNI

'Kolor znak-logotip horizontalni' sekundarni je odnos znak-logotip. Upotrebljava se kada tehnika reprodukcije ne dopušta korištenje 'akvel znak-logotip horizontalni'. (npr. sitotisak, oslikavanje, tampon tisak, katiranje, štik itd.)

CRNO-BIJELI ZNAK-LOGOTIP HORIZONTALNI

'Crno-bijeli znak-logotip horizontalni' tercijarni je odnos znak-logotip. Upotrebljava se isključivo u situacijama kada je nemoguća kolor reprodukcija ili dizajn zahtjeva monokromatski znak-logotip. (npr. gravura, katiranje itd.)

POZITIV

AKVAREL ZNAK-LOGOTIP HORIZONTALNI
'Akvel znak-logotip horizontalni' primarni je odnos znak-logotip i preporuča se njegovo korištenje gdje god tehnika reprodukcije i sam dizajn to dopuštaju.

KOLOR ZNAK-LOGOTIP HORIZONTALNI

'Kolor znak-logotip horizontalni' sekundarni je odnos znak-logotip. Upotrebljava se kada tehnika reprodukcije ne dopušta korištenje 'akvel znak-logotip horizontalni'. (npr. sitotisak, oslikavanje, tampon tisak, katiranje, štik itd.)

CRNO-BIJELI ZNAK-LOGOTIP HORIZONTALNI

'Crno-bijeli znak-logotip horizontalni' tercijarni je odnos znak-logotip. Upotrebljava se isključivo u situacijama kada je nemoguća kolor reprodukcija ili dizajn zahtjeva monokromatski znak-logotip. (npr. gravura, žig itd.)



↑
AKVAREL ZNAK-LOGOTIP HORIZONTALNI NEGATIV



↑
KOLOR ZNAK-LOGOTIP HORIZONTALNI NEGATIV



↑
CRNO-BIJELI ZNAK-LOGOTIP HORIZONTALNI NEGATIV



↑
AKVAREL ZNAK-LOGOTIP HORIZONTALNI POZITIV



↑
KOLOR ZNAK-LOGOTIP HORIZONTALNI POZITIV



↑
CRNO-BIJELI ZNAK-LOGOTIP HORIZONTALNI POZITIV

Dimenzije

Dimenzije odnosa znak-logotip određuju se kako bi se stvorio kontinuitet veličina.

POZITIV

Minimalna veličina horizontalnog odnosa znak-logotip je 34 x 12 mm. Horizontalni znak-logotip se ne smije upotrebljavati manji od te dimenzije.

Za znak-logotip koji se upotrebljava u većim dimenzijama od ovdje ilustriranih vrijedi isto progresivno pravilo povećavanja - 300% x, 400% x, 500% x, 600% x, 700% x, 800% x, 900% x...

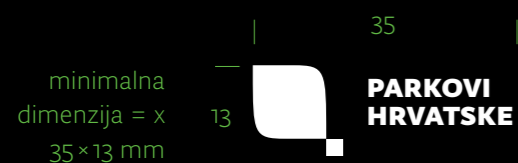
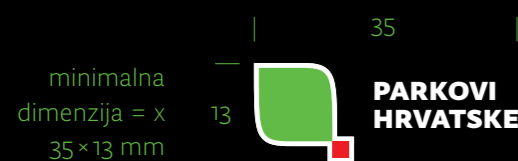
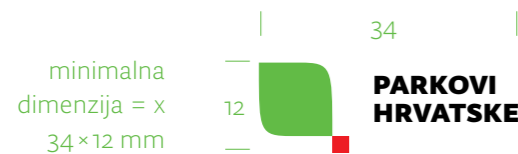

NEGATIV

Minimalna veličina horizontalnog odnosa znak-logotip je 35 x 13 mm. Horizontalni znak-logotip se ne smije upotrebljavati manji od te dimenzije.

Za znak-logotip koji se upotrebljava u većim dimenzijama od ovdje ilustriranih vrijedi isto progresivno pravilo povećavanja - 300% x, 400% x, 500% x, 600% x, 700% x, 800% x, 900% x...

Minimalni zaštitni prostor

Minimalni zaštitni prostor odnosa znak-logotip je prostor oko znak-logotipa u kojem se ne smiju nalaziti drugi grafički elementi kako se ne bi narušio integritet samog znaka.

Minimalni prostor određen je prema dimenziji a i prikazan je lijevo (točkasti pravokutnik).

Minimalni prostor mijenja se proporcionalno sa dimenzijom samog odnosa znak-logotip.

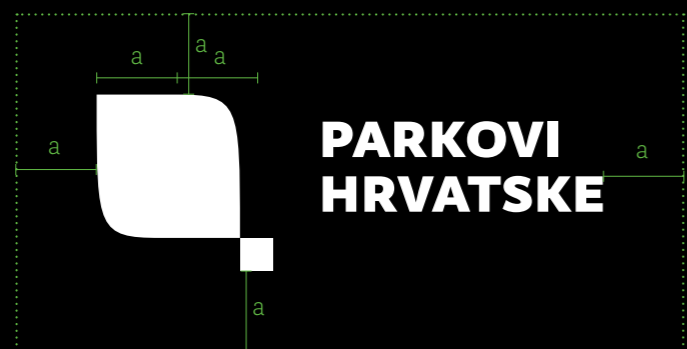
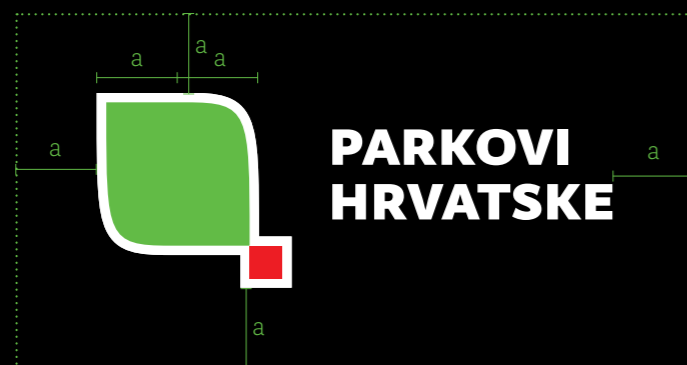

Apliciranje

AKROMATSKE KONTINUIRANE PODLOGE

Akromatske kontinuirane podloge su ravnomjerne podloge sivog spektra.

Znak-logotip se aplicira u negativu na sve akromatske kontinuirane podloge tamnije ili jednake 50% crne.

Znak-logotip se aplicira u pozitivu na sve akromatske kontinuirane podloge svijetlije od 50% crne.



C: 0, M: 0, Y: 0, K: 100



C: 0, M: 0, Y: 0, K: 90



C: 0, M: 0, Y: 0, K: 80



C: 0, M: 0, Y: 0, K: 70



C: 0, M: 0, Y: 0, K: 50



C: 0, M: 0, Y: 0, K: 0



C: 0, M: 0, Y: 0, K: 10



C: 0, M: 0, Y: 0, K: 20



C: 0, M: 0, Y: 0, K: 30



C: 0, M: 0, Y: 0, K: 40

Apliciranje

KROMATSKE KONTINUIRANE PODLOGE

Kromatske kontinuirane podloge su ravnomjerne obojane podloge.

Znak-logotip se aplicira u negativu na sve kromatske kontinuirane podloge tamnije ili jednake 50% crne.

Znak-logotip se aplicira u pozitivu na sve kromatske kontinuirane podloge svjetlije od 50% crne.



C: 100, M: 0, Y: 100, K: 20, grayscale ekvivalent 61%



C: 100, M: 0, Y: 100, K: 20, grayscale ekvivalent 30%



C: 100, M: 60, Y: 0, K: 0, grayscale ekvivalent 65%



C: 85, M: 0, Y: 0, K: 0, grayscale ekvivalent 25%

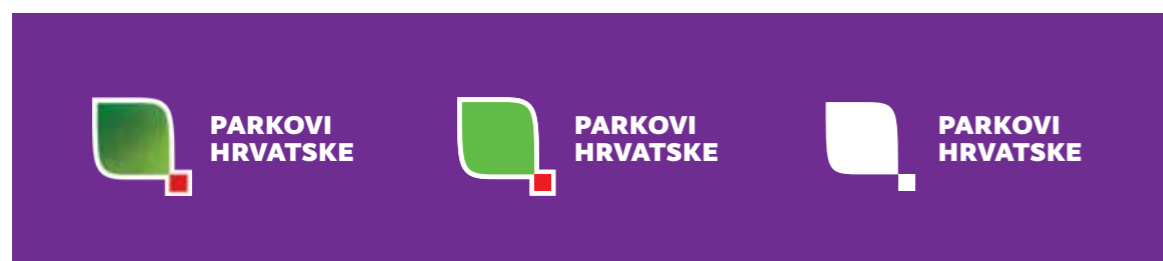

C: 70, M: 100, Y: 0, K: 0, grayscale ekvivalent 80%



C: 30, M: 60, Y: 0, K: 0, grayscale ekvivalent 44%



C: 0, M: 100, Y: 100, K: 5, grayscale ekvivalent 50%



C: 0, M: 50, Y: 100, K: 0, grayscale ekvivalent 40%



C: 0, M: 65, Y: 100, K: 50, grayscale ekvivalent 99%



C: 0, M: 10, Y: 70, K: 10, grayscale ekvivalent 24%



**PARKOVI
HRVATSKE**



**PARKOVI
HRVATSKE**



**PARKOVI
HRVATSKE**



~~**PARKOVI
HRVATSKE**~~



~~**PARKOVI
HRVATSKE**~~



~~**PARKOVI
HRVATSKE**~~



**PARKOVI
HRVATSKE**



**PARKOVI
HRVATSKE**



**PARKOVI
HRVATSKE**

**ZNAK ZAŠTITE PRIRODE I LOGOTIP
PARKOVI HRVATSKE**

Apliciranje

DISKONTINUIRANE PODLOGE

Diskontinuirana podloga je fotografska ili grafička podloga koja nije jednobojna.

Akvarel i kolor znak-logotip aplicira se u negativu na sve diskontinuirane podloge kojima je srednja svjetlina tamnija ili jednaka 50% crne.

Akvarel i kolor znak-logotip aplicira se u pozitivu na sve diskontinuirane podloge kojima je srednja svjetlina svjetlija od 50% crne.

Treba izbjegavati aplikaciju znaka-logotipa na diskontinuiranu podlogu koja je toliko heterogena da logotip (i pozitiv i negativ verzija) postaje nečitak.

Zabrane

ZABRANJENE APLIKACIJE I MANIPULACIJE

Odnos znak-logotip se nikada ne smije deformirati (sužavati, izduživati, skraćivati, rotirati...). Odnos znak-logotip strogo je propisan, te se svako njegovo narušavanje smatra deformacijom.

Dozvoljena apliciranja znaka-logotipa na razne pozadine ovise o njegovoj čitkosti i nenarušavanju vizualne komunikativnosti.

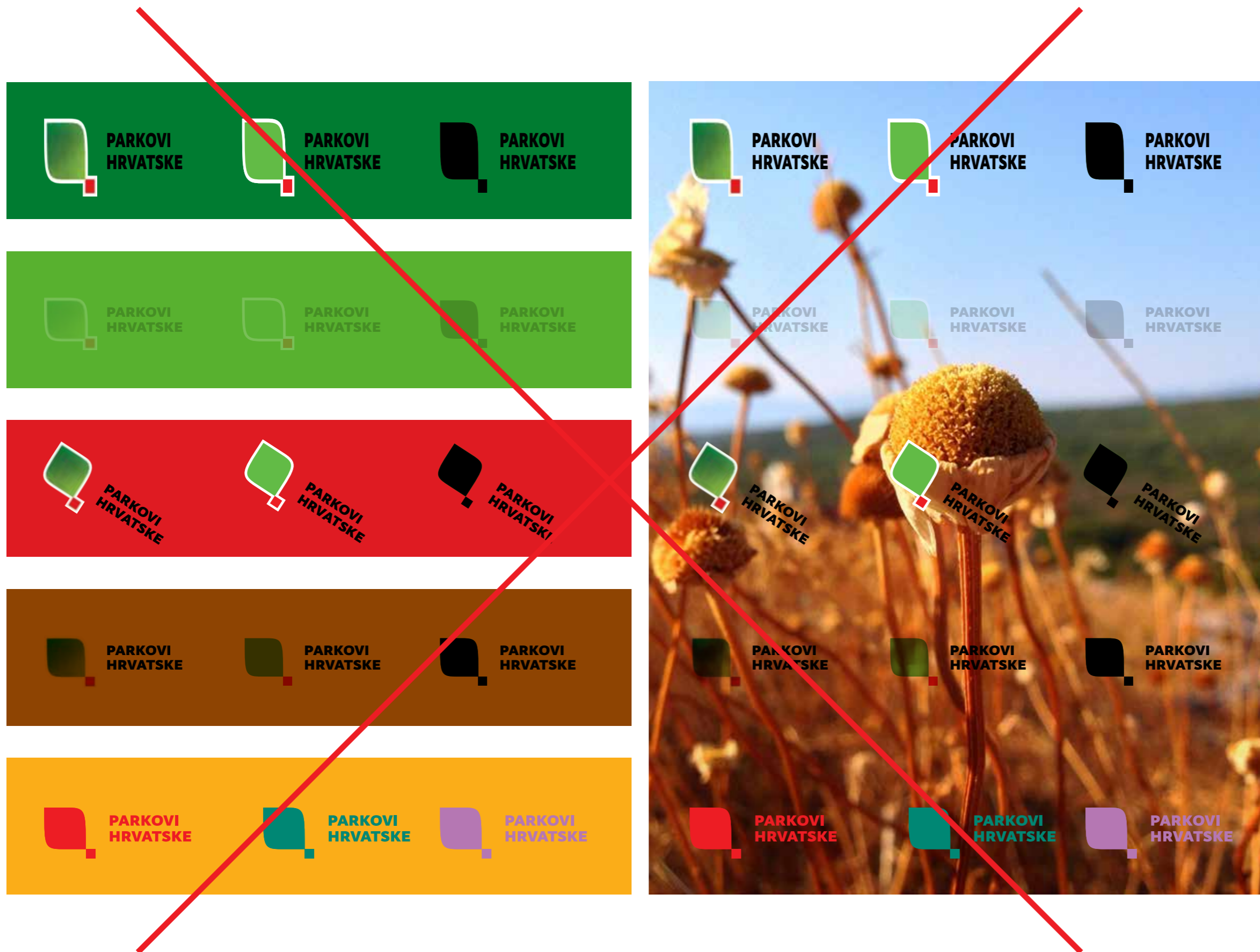

Horizontalni odnosi

NEGATIV

AKVAREL ZNAK-LOGOTIP HORIZONTALNI
'Akvel znak-logotip horizontalni' primarni je odnos znak-logotip i preporuča se njegovo korištenje gdje god tehnika reprodukcije i sam dizajn to dopuštaju.

KOLOR ZNAK-LOGOTIP HORIZONTALNI

'Kolor znak-logotip horizontalni' sekundarni je odnos znak-logotip. Upotrebljava se kada tehnika reprodukcije ne dopušta korištenje 'akvel znak-logotip horizontalni'. (npr. sitotisak, oslikavanje, tampon tisak, katiranje, štik itd.)

CRNO-BIJELI ZNAK-LOGOTIP HORIZONTALNI

'Crno-bijeli znak-logotip horizontalni' tercijarni je odnos znak-logotip. Upotrebljava se isključivo u situacijama kada je nemoguća kolor reprodukcija ili dizajn zahtjeva monokromatski znak-logotip. (npr. gravura, katiranje itd.)

POZITIV

AKVAREL ZNAK-LOGOTIP HORIZONTALNI
'Akvel znak-logotip horizontalni' primarni je odnos znak-logotip i preporuča se njegovo korištenje gdje god tehnika reprodukcije i sam dizajn to dopuštaju.

KOLOR ZNAK-LOGOTIP HORIZONTALNI

'Kolor znak-logotip horizontalni' sekundarni je odnos znak-logotip. Upotrebljava se kada tehnika reprodukcije ne dopušta korištenje 'akvel znak-logotip horizontalni'. (npr. sitotisak, oslikavanje, tampon tisak, katiranje, štik itd.)

CRNO-BIJELI ZNAK-LOGOTIP HORIZONTALNI

'Crno-bijeli znak-logotip horizontalni' tercijarni je odnos znak-logotip. Upotrebljava se isključivo u situacijama kada je nemoguća kolor reprodukcija ili dizajn zahtjeva monokromatski znak-logotip. (npr. gravura, žig itd.)



↑
AKVAREL ZNAK-LOGOTIP HORIZONTALNI NEGATIV



↑
KOLOR ZNAK-LOGOTIP HORIZONTALNI NEGATIV



↑
CRNO-BIJELI ZNAK-LOGOTIP HORIZONTALNI NEGATIV

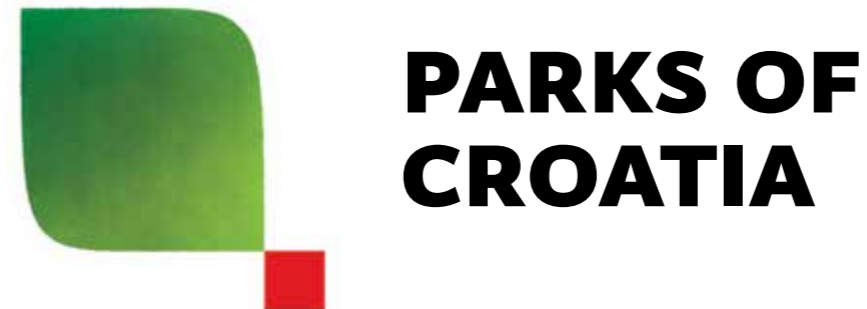

↑
AKVAREL ZNAK-LOGOTIP HORIZONTALNI POZITIV



↑
KOLOR ZNAK-LOGOTIP HORIZONTALNI POZITIV



↑
CRNO-BIJELI ZNAK-LOGOTIP HORIZONTALNI POZITIV

Dimenzije

Dimenzije odnosa znak-logotip određuju se kako bi se stvorio kontinuitet veličina.

POZITIV

Minimalna veličina horizontalnog odnosa znak-logotip je 33 x 12 mm. Horizontalni znak-logotip se ne smije upotrebljavati manji od te dimenzije.

Za znak-logotip koji se upotrebljava u većim dimenzijama od ovdje ilustriranih vrijedi isto progresivno pravilo povećavanja - 300% x, 400% x, 500% x, 600% x, 700% x, 800% x, 900% x...

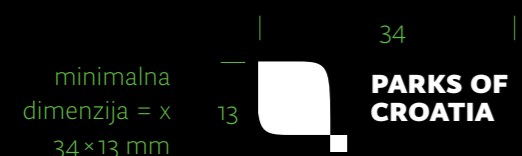
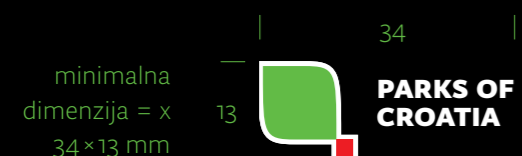
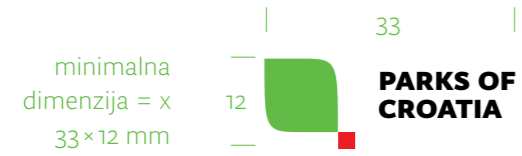

NEGATIV

Minimalna veličina horizontalnog odnosa znak-logotip je 34 x 13 mm. Horizontalni znak-logotip se ne smije upotrebljavati manji od te dimenzije.

Za znak-logotip koji se upotrebljava u većim dimenzijama od ovdje ilustriranih vrijedi isto progresivno pravilo povećavanja - 300% x, 400% x, 500% x, 600% x, 700% x, 800% x, 900% x...

Minimalni zaštitni prostor

Minimalni zaštitni prostor odnosa znak-logotip je prostor oko znak-logotipa u kojem se ne smiju nalaziti drugi grafički elementi kako se ne bi narušio integritet samog znaka.

Minimalni prostor određen je prema dimenziji a i prikazan je lijevo (točkasti pravokutnik).

Minimalni prostor mijenja se proporcionalno sa dimenzijom samog odnosa znak-logotip.

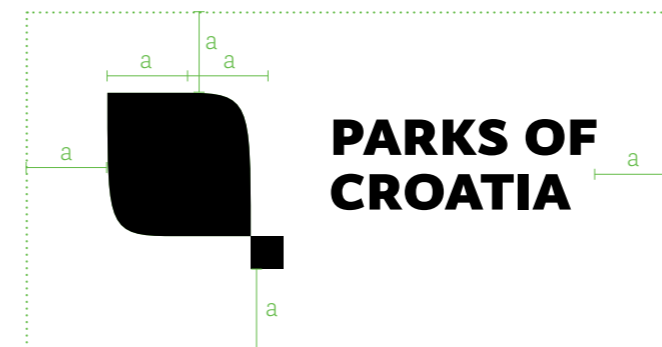
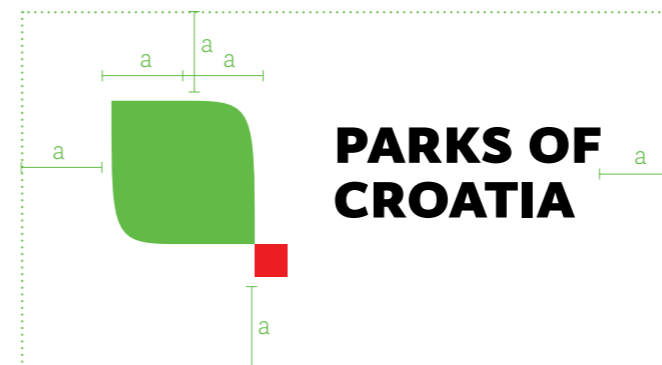
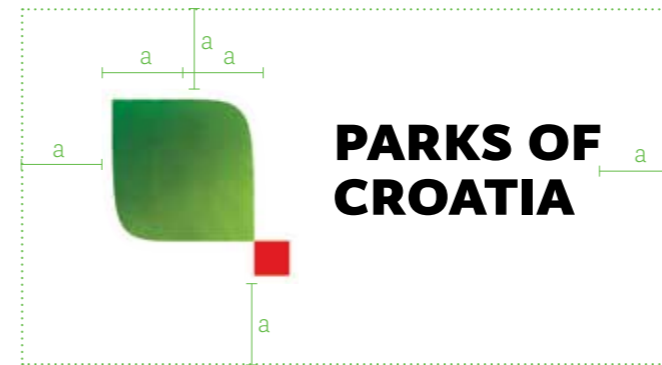
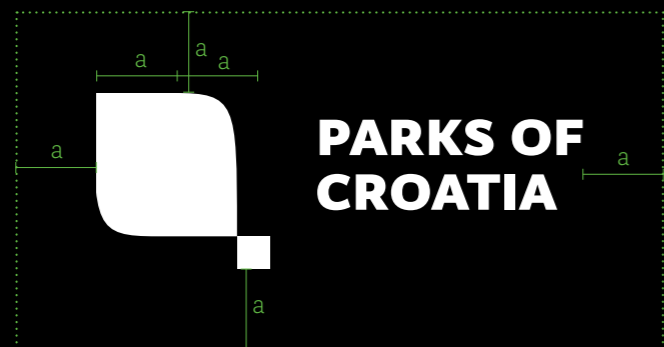
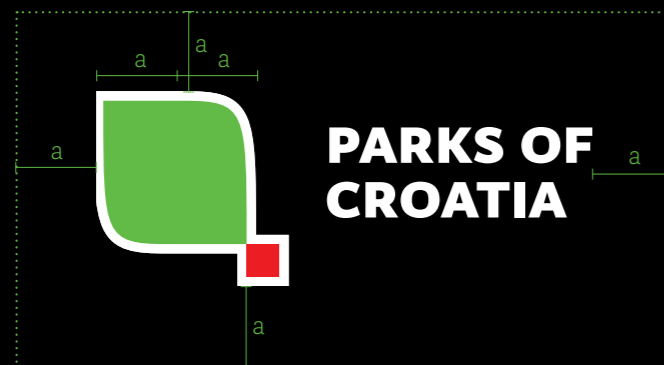
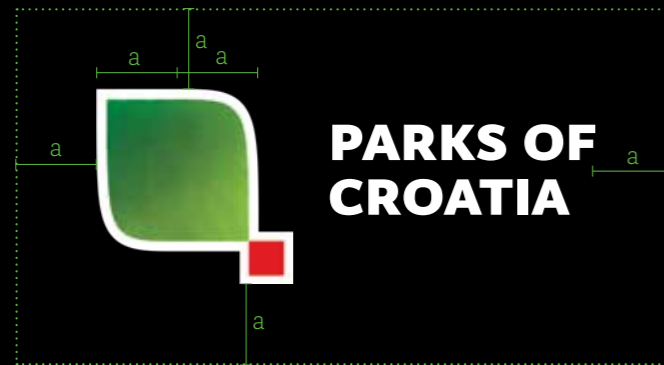

Apliciranje

AKROMATSKE KONTINUIRANE PODLOGE

Akromatske kontinuirane podloge su ravnomjerne podloge sivog spektra.

Znak-logotip se aplicira u negativu na sve akromatske kontinuirane podloge tamnije ili jednake 50% crne.

Znak-logotip se aplicira u pozitivu na sve akromatske kontinuirane podloge svjetlije od 50% crne.



C: 0, M: 0, Y: 0, K: 100



C: 0, M: 0, Y: 0, K: 90



C: 0, M: 0, Y: 0, K: 80



C: 0, M: 0, Y: 0, K: 70



C: 0, M: 0, Y: 0, K: 50



C: 0, M: 0, Y: 0, K: 0

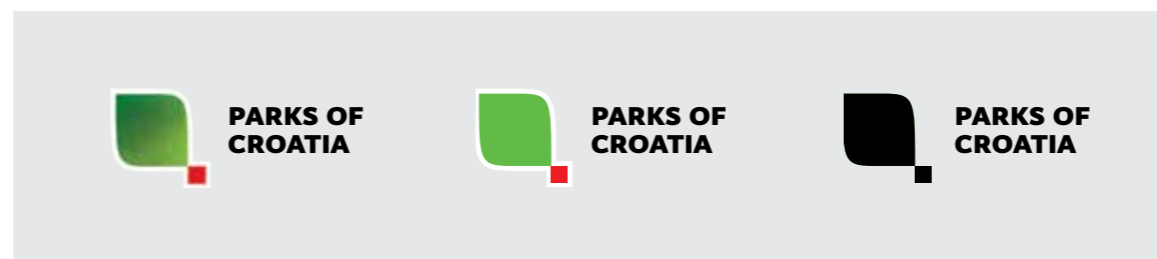

C: 0, M: 0, Y: 0, K: 10



C: 0, M: 0, Y: 0, K: 20

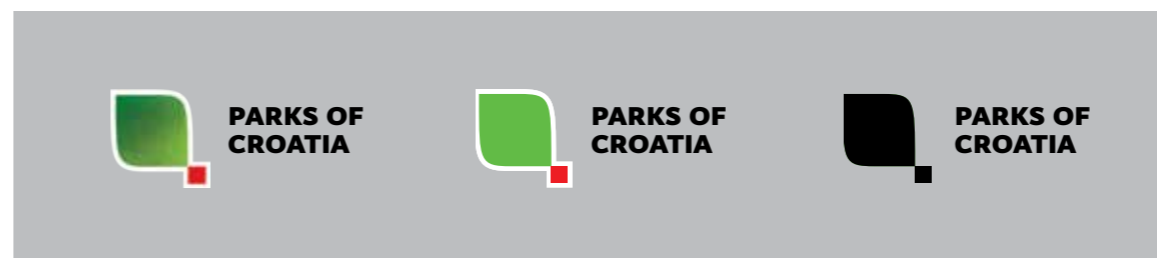

C: 0, M: 0, Y: 0, K: 30

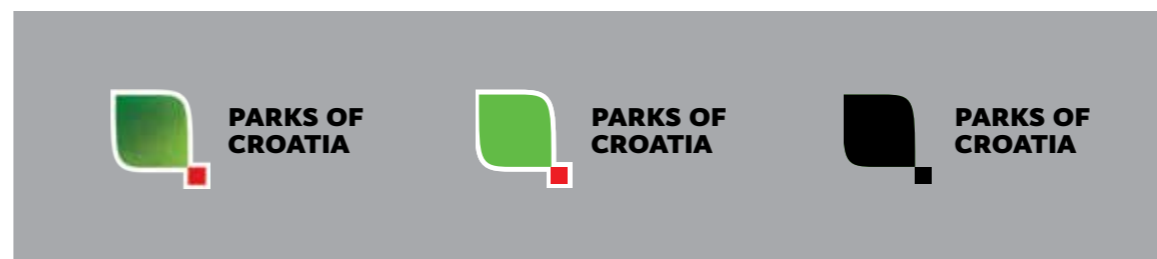

C: 0, M: 0, Y: 0, K: 40

Apliciranje

KROMATSKE KONTINUIRANE PODLOGE

Kromatske kontinuirane podloge su ravnomjerne obojane podloge.

Znak-logotip se aplicira u negativu na sve kromatske kontinuirane podloge tamnije ili jednake 50% crne.

Znak-logotip se aplicira u pozitivu na sve kromatske kontinuirane podloge svjetlije od 50% crne.



C: 100, M: 0, Y: 100, K: 20, grayscale ekvivalent 61%



C: 100, M: 0, Y: 100, K: 20, grayscale ekvivalent 30%



C: 100, M: 60, Y: 0, K: 0, grayscale ekvivalent 65%



C: 85, M: 0, Y: 0, K: 0, grayscale ekvivalent 25%



C: 70, M: 100, Y: 0, K: 0, grayscale ekvivalent 80%

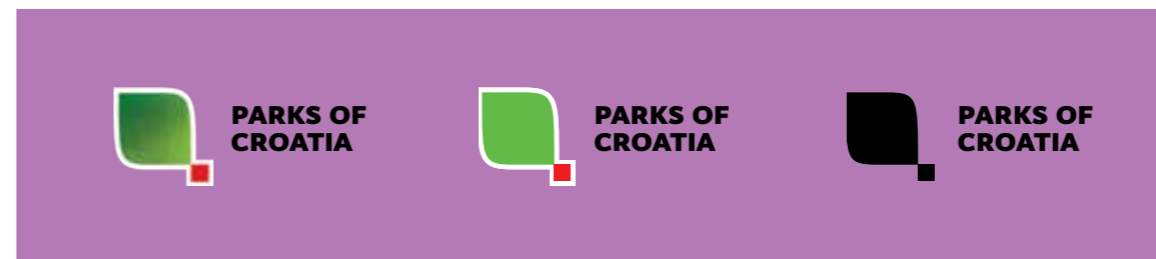

C: 30, M: 60, Y: 0, K: 0, grayscale ekvivalent 44%



C: 0, M: 100, Y: 100, K: 5, grayscale ekvivalent 50%

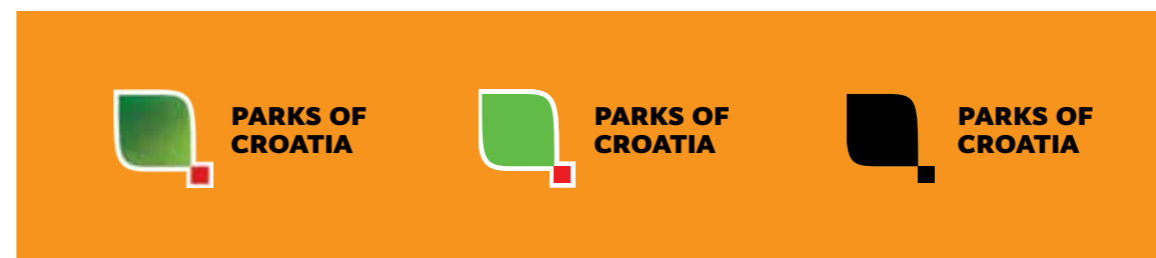

C: 0, M: 50, Y: 100, K: 0, grayscale ekvivalent 40%



C: 0, M: 65, Y: 100, K: 50, grayscale ekvivalent 99%

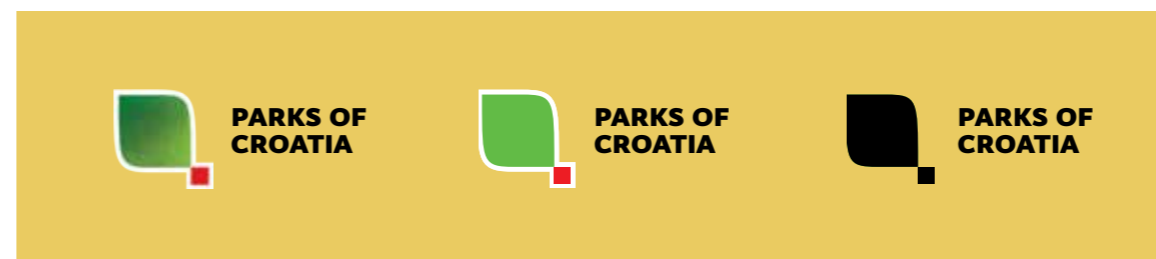

C: 0, M: 10, Y: 70, K: 10, grayscale ekvivalent 24%

Apliciranje

DISKONTINUIRANE PODLOGE

Diskontinuirana podloga je fotografska ili grafička podloga koja nije jednobojna.

Akvarel i kolor znak-logotip aplicira se u negativu na sve diskontinuirane podloge kojima je srednja svjetlina tamnija ili jednaka 50% crne.

Akvarel i kolor znak-logotip aplicira se u pozitivu na sve diskontinuirane podloge kojima je srednja svjetlina svjetlija od 50% crne.

Treba izbjegavati aplikaciju znaka-logotipa na diskontinuiranu podlogu koja je toliko heterogena da logotip (i pozitiv i negativ verzija) postaje nečitak.



Zabrane

ZABRANJENE APLIKACIJE I MANIPULACIJE

Odnos znak-logotip se nikada ne smije deformirati (sužavati, izduživati, skraćivati, rotirati...). Odnos znak-logotip strogo je propisan, te se svako njegovo narušavanje smatra deformacijom.

Dozvoljena apliciranja znaka-logotipa na razne pozadine ovise o njegovoj čitkosti i nenarušavanju vizualne komunikativnosti.

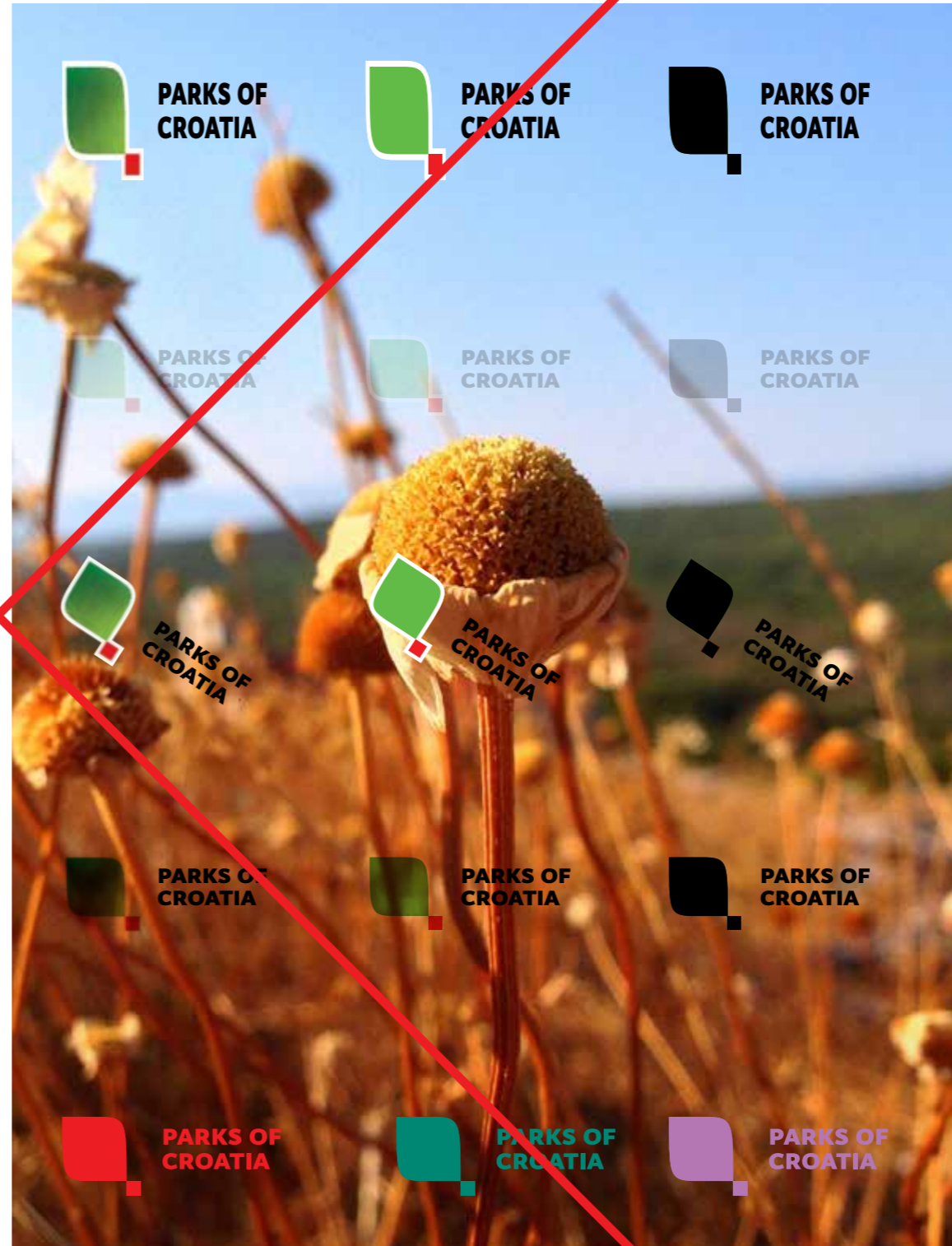

Horizontalni odnosi

NEGATIV

AKVAREL ZNAK-LOGOTIP HORIZONTALNI
'Akvel znak-logotip horizontalni' primarni je odnos znak-logotip i preporuča se njegovo korištenje gdje god tehnika reprodukcije i sam dizajn to dopuštaju.

KOLOR ZNAK-LOGOTIP HORIZONTALNI

'Kolor znak-logotip horizontalni' sekundarni je odnos znak-logotip. Upotrebljava se kada tehnika reprodukcije ne dopušta korištenje 'akvel znak-logotip horizontalni'. (npr. sitotisak, oslikavanje, tampon tisak, katiranje, štik itd.)

CRNO-BIJELI ZNAK-LOGOTIP HORIZONTALNI

'Crno-bijeli znak-logotip horizontalni' tercijarni je odnos znak-logotip. Upotrebljava se isključivo u situacijama kada je nemoguća kolor reprodukcija ili dizajn zahtjeva monokromatski znak-logotip. (npr. gravura, katiranje itd.)

POZITIV

AKVAREL ZNAK-LOGOTIP HORIZONTALNI
'Akvel znak-logotip horizontalni' primarni je odnos znak-logotip i preporuča se njegovo korištenje gdje god tehnika reprodukcije i sam dizajn to dopuštaju.

KOLOR ZNAK-LOGOTIP HORIZONTALNI

'Kolor znak-logotip horizontalni' sekundarni je odnos znak-logotip. Upotrebljava se kada tehnika reprodukcije ne dopušta korištenje 'akvel znak-logotip horizontalni'. (npr. sitotisak, oslikavanje, tampon tisak, katiranje, štik itd.)

CRNO-BIJELI ZNAK-LOGOTIP HORIZONTALNI

'Crno-bijeli znak-logotip horizontalni' tercijarni je odnos znak-logotip. Upotrebljava se isključivo u situacijama kada je nemoguća kolor reprodukcija ili dizajn zahtjeva monokromatski znak-logotip. (npr. gravura, žig itd.)



↑
AKVAREL ZNAK-LOGOTIP HORIZONTALNI NEGATIV



↑
KOLOR ZNAK-LOGOTIP HORIZONTALNI NEGATIV



↑
CRNO-BIJELI ZNAK-LOGOTIP HORIZONTALNI NEGATIV



↑
AKVAREL ZNAK-LOGOTIP HORIZONTALNI POZITIV



↑
KOLOR ZNAK-LOGOTIP HORIZONTALNI POZITIV



↑
CRNO-BIJELI ZNAK-LOGOTIP HORIZONTALNI POZITIV

Dimenzije

Dimenzije odnosa znak-logotip određuju se kako bi se stvorio kontinuitet veličina.

POZITIV

Minimalna veličina horizontalnog odnosa znak-logotip je 38 × 12 mm. Horizontalni znak-logotip se ne smije upotrebljavati manji od te dimenzije.

Za znak-logotip koji se upotrebljava u većim dimenzijama od ovdje ilustriranih vrijedi isto progresivno pravilo povećavanja - 300% x, 400% x, 500% x, 600% x, 700% x, 800% x, 900% x...

NEGATIV

Minimalna veličina horizontalnog odnosa znak-logotip je 38 × 13 mm. Horizontalni znak-logotip se ne smije upotrebljavati manji od te dimenzije.

Za znak-logotip koji se upotrebljava u većim dimenzijama od ovdje ilustriranih vrijedi isto progresivno pravilo povećavanja - 300% x, 400% x, 500% x, 600% x, 700% x, 800% x, 900% x...

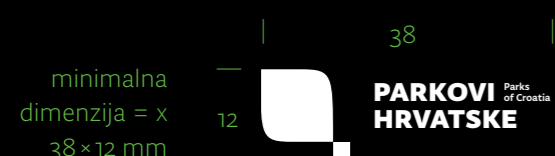
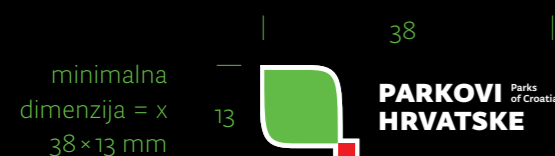
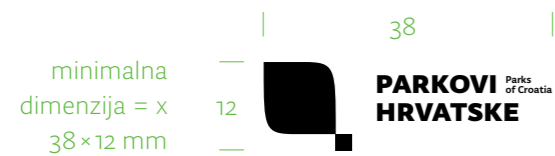
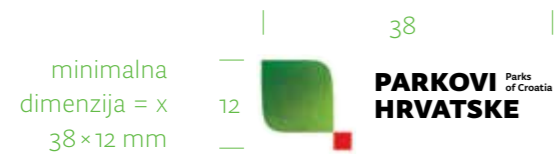

Minimalni zaštitni prostor

Minimalni zaštitni prostor odnosa znak-logotip je prostor oko znak-logotipa u kojem se ne smiju nalaziti drugi grafički elementi kako se ne bi narušio integritet samog znaka.

Minimalni prostor određen je prema dimenziji a i prikazan je lijevo (točkasti pravokutnik).

Minimalni prostor mijenja se proporcionalno sa dimenzijom samog odnosa znak-logotip.



Apliciranje

AKROMATSKE KONTINUIRANE PODLOGE

Akromatske kontinuirane podloge su ravnomjerne podloge sivog spektra.

Znak-logotip se aplicira u negativu na sve akromatske kontinuirane podloge tamnije ili jednake 50% crne.

Znak-logotip se aplicira u pozitivu na sve akromatske kontinuirane podloge svijetlije od 50% crne.



C: 0, M: 0, Y: 0, K: 100



C: 0, M: 0, Y: 0, K: 90



C: 0, M: 0, Y: 0, K: 80



C: 0, M: 0, Y: 0, K: 70



C: 0, M: 0, Y: 0, K: 50



C: 0, M: 0, Y: 0, K: 0



C: 0, M: 0, Y: 0, K: 10



C: 0, M: 0, Y: 0, K: 20



C: 0, M: 0, Y: 0, K: 30



C: 0, M: 0, Y: 0, K: 40

Apliciranje

KROMATSKE KONTINUIRANE PODLOGE

Kromatske kontinuirane podloge su
ravnomyjerne obojane podloge.

Znak-logotip se aplicira u negativu na
sve kromatske kontinuirane podloge
tamnije ili jednake 50% crne.

Znak-logotip se aplicira u pozitivu na
sve kromatske kontinuirane podloge
svijetlije od 50% crne.



C: 100, M: 0, Y: 100, K: 20, grayscale ekvivalent 61%



C: 100, M: 0, Y: 100, K: 20, grayscale ekvivalent 30%



C: 100, M: 60, Y: 0, K: 0, grayscale ekvivalent 65%



C: 85, M: 0, Y: 0, K: 0, grayscale ekvivalent 25%



C: 70, M: 100, Y: 0, K: 0, grayscale ekvivalent 80%



C: 30, M: 60, Y: 0, K: 0, grayscale ekvivalent 44%



C: 0, M: 100, Y: 100, K: 5, grayscale ekvivalent 50%



C: 0, M: 50, Y: 100, K: 0, grayscale ekvivalent 40%



C: 0, M: 65, Y: 100, K: 50, grayscale ekvivalent 99%

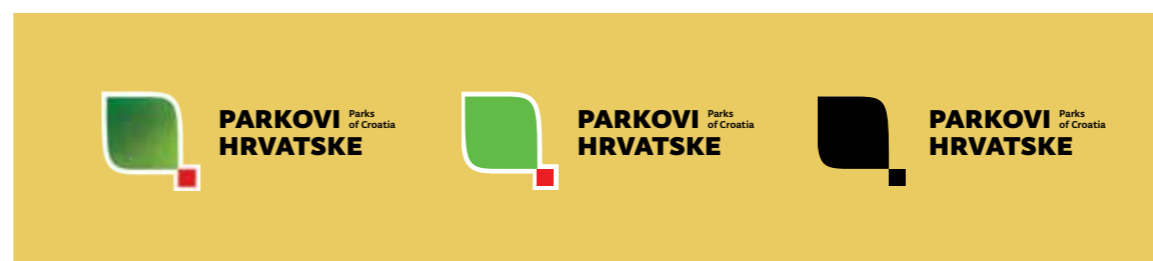

C: 0, M: 10, Y: 70, K: 10, grayscale ekvivalent 24%

Apliciranje

DISKONTINUIRANE PODLOGE

Diskontinuirana podloga je fotografska ili grafička podloga koja nije jednobojna.

Akvarel i kolor znak-logotip aplicira se u negativu na sve diskontinuirane podloge kojima je srednja svjetlina tamnija ili jednaka 50% crne.

Akvarel i kolor znak-logotip aplicira se u pozitivu na sve diskontinuirane podloge kojima je srednja svjetlina svjetlija od 50% crne.

Treba izbjegavati aplikaciju znaka-logotipa na diskontinuiranu podlogu koja je toliko heterogena da logotip (i pozitiv i negativ verzija) postaje nečitak.



Zabrane

ZABRANJENE APLIKACIJE I MANIPULACIJE

Odnos znak-logotip se nikada ne smije deformirati (sužavati, izduživati, skraćivati, rotirati...). Odnos znak-logotip strogo je propisan, te se svako njegovo narušavanje smatra deformacijom.

Dozvoljena apliciranja znaka-logotipa na razne pozadine ovise o njegovoj čitkosti i nenarušavanju vizualne komunikativnosti.

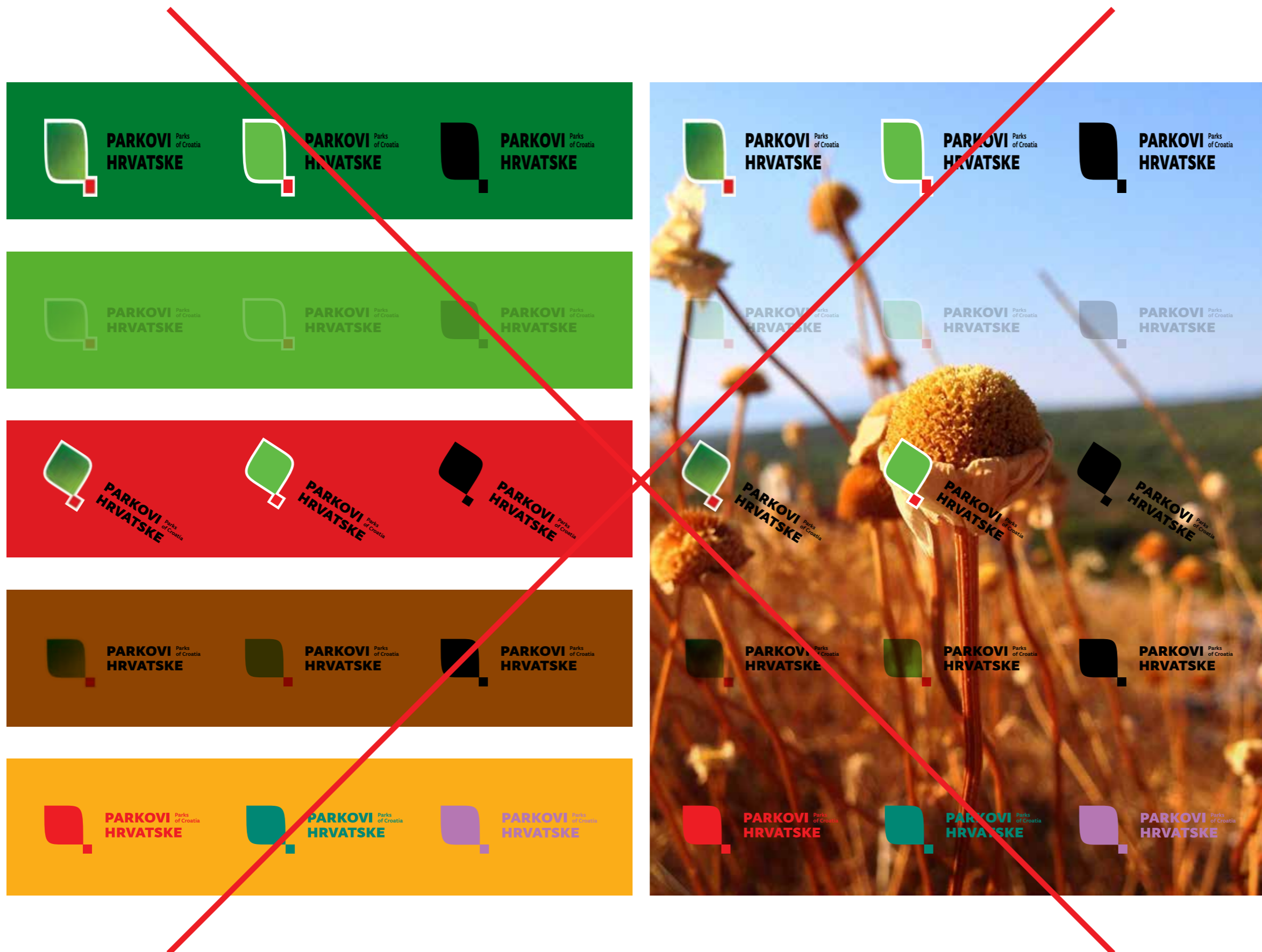



↑
AKVAREL ZNAK-LOGOTIP VERTIKALNI NEGATIV



↑
KOLOR ZNAK-LOGOTIP VERTIKALNI NEGATIV



↑
CRNO-BIJELI ZNAK-LOGOTIP VERTIKALNI NEGATIV



↑
AKVAREL ZNAK-LOGOTIP VERTIKALNI POZITIV



↑
KOLOR ZNAK-LOGOTIP VERTIKALNI POZITIV



↑
CRNO-BIJELI ZNAK-LOGOTIP HVERTIKALNI POZITIV

ZNAK ZAŠTITE PRIRODE I LOGOTIP PARKOVI HRVATSKE

Vertikalni odnosi

NEGATIV

AKVAREL ZNAK-LOGOTIP VERTIKALNI

'Akvarel znak-logotip vertikalni' primarni je odnos znak-logotip i preporuča se njegovo korištenje gdje god tehnika reprodukcije i sam dizajn to dopuštaju.

KOLOR ZNAK-LOGOTIP VERTIKALNI

'Kolor znak-logotip vertikalni' sekundarni je odnos znak-logotip. Upotrebljava se kada tehnika reprodukcije ne dopušta korištenje 'akvarel znak-logotip horizontalni'. (npr. sitotisak, oslikavanje, tampon tisak, katiranje, štik itd.)

CRNO-BIJELI ZNAK-LOGOTIP VERTIKALNI

'Crno-bijeli znak-logotip vertikalni' tercijarni je odnos znak-logotip. Upotrebljava se isključivo u situacijama kada je nemoguća kolor reprodukcija ili dizajn zahtjeva monokromatski znak-logotip. (npr. gravura, katiranje itd.)

POZITIV

AKVAREL ZNAK-LOGOTIP VERTIKALNI

'Akvarel znak-logotip vertikalni' primarni je odnos znak-logotip i preporuča se njegovo korištenje gdje god tehnika reprodukcije i sam dizajn to dopuštaju.

KOLOR ZNAK-LOGOTIP VERTIKALNI

'Kolor znak-logotip vertikalni' sekundarni je odnos znak-logotip. Upotrebljava se kada tehnika reprodukcije ne dopušta korištenje 'akvarel znak-logotip horizontalni'. (npr. sitotisak, oslikavanje, tampon tisak, katiranje, štik itd.)

CRNO-BIJELI ZNAK-LOGOTIP VERTIKALNI

'Crno-bijeli znak-logotip vertikalni' tercijarni je odnos znak-logotip. Upotrebljava se isključivo u situacijama kada je nemoguća kolor reprodukcija ili dizajn zahtjeva monokromatski znak-logotip. (npr. gravura, žig itd.)

Dimenzije

Dimenzije odnosa znak-logotip određuju se kako bi se stvorio kontinuitet veličina.

POZITIV

Minimalna veličina vertikalnog odnosa znak-logotip je 19 × 21 mm. Vertikalni znak-logotip se ne smije upotrebljavati manji od te dimenzije.

Za znak-logotip koji se upotrebljava u većim dimenzijama od ovdje ilustriranih vrijedi isto progresivno pravilo povećavanja - 300% x, 400% x, 500% x, 600% x, 700% x, 800% x, 900% x...



minimalna
dimenzija = x
19 × 21 mm



minimalna
dimenzija = x
19 × 21 mm



minimalna
dimenzija = x
19 × 21 mm



150% x



150% x



150% x



200% x



200% x



200% x

Dimenzije

Dimenzije odnosa znak-logotip određuju se kako bi se stvorio kontinuitet veličina.

NEGATIV

Minimalna veličina vertikalnog odnosa znak-logotip je 19 x 22 mm. Vertikalni znak-logotip se ne smije upotrebljavati manji od te dimenzije.

Za znak-logotip koji se upotrebljava u većim dimenzijama od ovdje ilustriranih vrijedi isto progresivno pravilo povećavanja - 300% x, 400% x, 500% x, 600% x, 700% x, 800% x, 900% x...



minimalna
dimenzija = x
19 x 22 mm

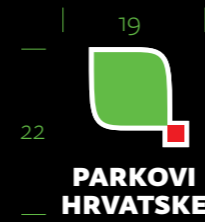

minimalna
dimenzija = x
19 x 22 mm



150% x



150% x



150% x



200% x



200% x



200% x

Minimalni zaštitni prostor

Minimalni zaštitni prostor odnosa znak-logotip je prostor oko znak-logotipa u kojem se ne smiju nalaziti drugi grafički elementi kako se ne bi narušio integritet samog znaka.

Minimalni prostor određen je prema dimenziji 'a' i prikazan je lijevo (točkasti pravokutnik).

Minimalni prostor mijenja se proporcionalno sa dimenzijom samog odnosa znak-logotip.



Apliciranje

AKROMATSKE KONTINUIRANE PODLOGE

Akromatske kontinuirane podloge su ravnomjerne podloge sivog spektra.

Znak-logotip se aplicira u negativu na sve akromatske kontinuirane podloge tamnije ili jednake 50% crne.

Znak-logotip se aplicira u pozitivu na sve akromatske kontinuirane podloge svijetlije od 50% crne.



C: 0, M: 0, Y: 0, K: 100



C: 0, M: 0, Y: 0, K: 90



C: 0, M: 0, Y: 0, K: 80



C: 0, M: 0, Y: 0, K: 70



C: 0, M: 0, Y: 0, K: 50



C: 0, M: 0, Y: 0, K: 0



C: 0, M: 0, Y: 0, K: 10



C: 0, M: 0, Y: 0, K: 20



C: 0, M: 0, Y: 0, K: 30



C: 0, M: 0, Y: 0, K: 40

Apliciranje

KROMATSKE KONTINUIRANE PODLOGE

Kromatske kontinuirane podloge su ravnomjerne obojane podloge.

Znak-logotip se aplicira u negativu na sve kromatske kontinuirane podloge tamnije ili jednake 50% crne.

Znak-logotip se aplicira u pozitivu na sve kromatske kontinuirane podloge svjetlije od 50% crne.



C: 100, M: 0, Y: 100, K: 20, grayscale ekvivalent 61%



C: 100, M: 0, Y: 100, K: 20, grayscale ekvivalent 30%



C: 100, M: 60, Y: 0, K: 0, grayscale ekvivalent 65%

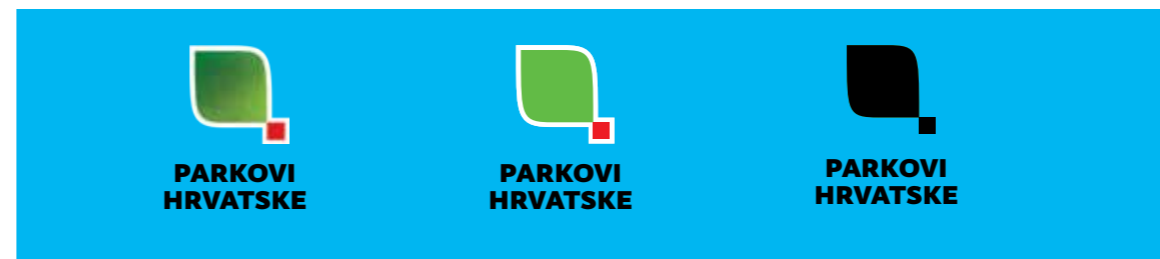

C: 85, M: 0, Y: 0, K: 0, grayscale ekvivalent 25%

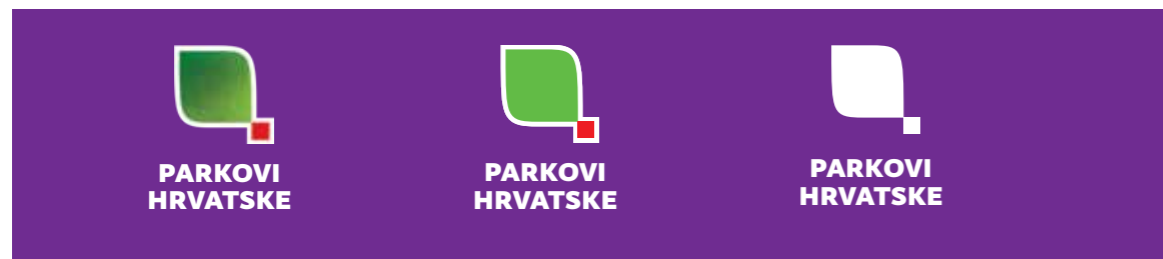

C: 70, M: 100, Y: 0, K: 0, grayscale ekvivalent 80%

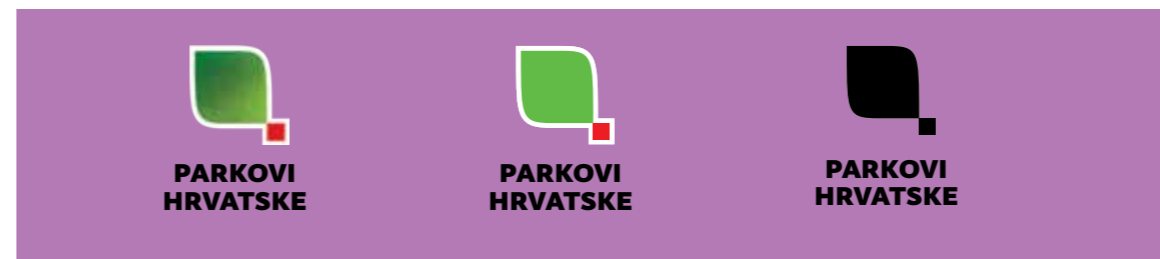

C: 30, M: 60, Y: 0, K: 0, grayscale ekvivalent 44%



C: 0, M: 100, Y: 100, K: 5, grayscale ekvivalent 50%



C: 0, M: 50, Y: 100, K: 0, grayscale ekvivalent 40%



C: 0, M: 65, Y: 100, K: 50, grayscale ekvivalent 99%

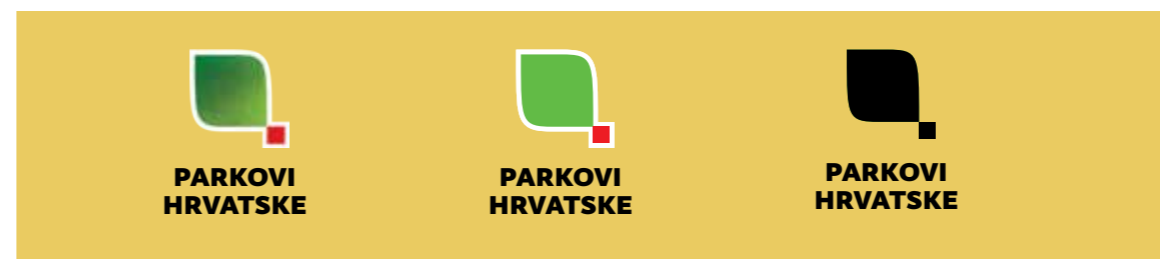

C: 0, M: 10, Y: 70, K: 10, grayscale ekvivalent 24%

Apliciranje

DISKONTINUIRANE PODLOGE

Diskontinuirana podloga je fotografska ili grafička podloga koja nije jednobojna.

Znak-logotip se aplicira u negativu) na sve diskontinuirane podloge kojima je srednja svjetlina tamnija ili jednaka 50% crne.

Znak-logotip se aplicira u pozitivu na sve diskontinuirane podloge kojima je srednja svjetlina svijetlija od 50% crne.

Treba izbjegavati aplikaciju znaka-logo-tipa na diskontinuiranu podlogu koja je toliko heterogena da logotip (i pozitiv i negativ verzija) postaje nečitak.



Zabrane

ZABRANJENE APLIKACIJE I MANIPULACIJE

Odnos znak-logotip se nikada ne smije deformirati (sužavati, izduživati, skraćivati, rotirati...). Odnos znak-logotip strogo je propisan, te se svako njegovo narušavanje smatra deformacijom.

Dozvoljena apliciranja znaka-logotipa na razne pozadine ovise o njegovoj čitkosti i nenarušavanju vizualne komunikativnosti.

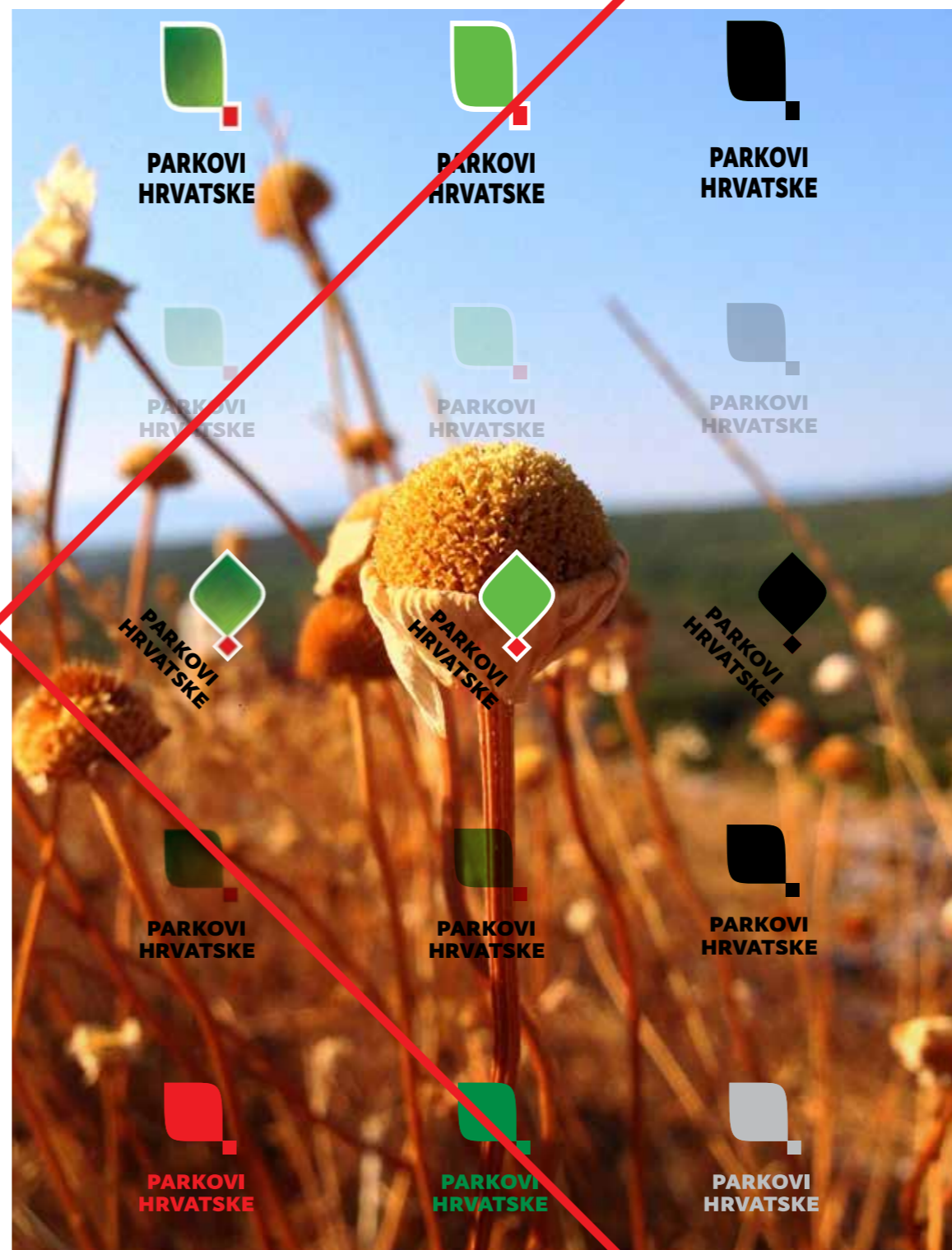



↑
AKVAREL ZNAK-LOGOTIP VERTIKALNI NEGATIV



↑
KOLOR ZNAK-LOGOTIP VERTIKALNI NEGATIV



↑
CRNO-BIJELI ZNAK-LOGOTIP VERTIKALNI NEGATIV



↑
AKVAREL ZNAK-LOGOTIP VERTIKALNI POZITIV



↑
KOLOR ZNAK-LOGOTIP VERTIKALNI POZITIV



↑
CRNO-BIJELI ZNAK-LOGOTIP HVERTIKALNI POZITIV

ZNAK ZAŠTITE PRIRODE I LOGOTIP PARKOVI HRVATSKE NA ENGLESKOM

Vertikalni odnos znak- logotip ENG

NEGATIV

AKVAREL ZNAK-LOGOTIP VERTIKALNI

'Akvarel znak-logotip vertikalni' primarni je odnos znak-logotip i preporuča se njegovo korištenje gdje god tehnika reprodukcije i sam dizajn to dopuštaju.

KOLOR ZNAK-LOGOTIP VERTIKALNI

'Kolor znak-logotip vertikalni' sekundarni je odnos znak-logotip. Upotrebljava se kada tehnika reprodukcije ne dopušta korištenje 'akvarel znak-logotip horizontalni'. (npr. sitotisak, oslikavanje, tampon tisak, katiranje, štik itd.)

CRNO-BIJELI ZNAK-LOGOTIP VERTIKALNI

'Crno-bijeli znak-logotip vertikalni' tercijarni je odnos znak-logotip. Upotrebljava se isključivo u situacijama kada je nemoguća kolor reprodukcija ili dizajn zahtjeva monokromatski znak-logotip. (npr. gravura, katiranje itd.)

POZITIV

AKVAREL ZNAK-LOGOTIP VERTIKALNI

'Akvarel znak-logotip vertikalni' primarni je odnos znak-logotip i preporuča se njegovo korištenje gdje god tehnika reprodukcije i sam dizajn to dopuštaju.

KOLOR ZNAK-LOGOTIP VERTIKALNI

'Kolor znak-logotip vertikalni' sekundarni je odnos znak-logotip. Upotrebljava se kada tehnika reprodukcije ne dopušta korištenje 'akvarel znak-logotip horizontalni'. (npr. sitotisak, oslikavanje, tampon tisak, katiranje, štik itd.)

CRNO-BIJELI ZNAK-LOGOTIP VERTIKALNI

'Crno-bijeli znak-logotip vertikalni' tercijarni je odnos znak-logotip. Upotrebljava se isključivo u situacijama kada je nemoguća kolor reprodukcija ili dizajn zahtjeva monokromatski znak-logotip. (npr. gravura, žig itd.)

Dimenzije

Dimenzije odnosa znak-logotip određuju se kako bi se stvorio kontinuitet veličina.

POZITIV

Minimalna veličina vertikalnog odnosa znak-logotip je 18 x 21 mm. Vertikalni znak-logotip se ne smije upotrebljavati manji od te dimenzije.

Za znak-logotip koji se upotrebljava u većim dimenzijama od ovdje ilustriranih vrijedi isto progresivno pravilo povećavanja - 300% x, 400% x, 500% x, 600% x, 700% x, 800% x, 900% x...

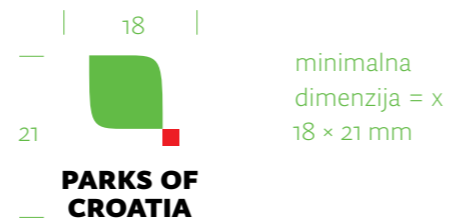

Dimenzije

Dimenzije odnosa znak-logotip određuju se kako bi se stvorio kontinuitet veličina.

NEGATIV

Minimalna veličina vertikalnog odnosa znak-logotip je 18 x 22 mm. Vertikalni znak-logotip se ne smije upotrebljavati manji od te dimenzije.

Za znak-logotip koji se upotrebljava u većim dimenzijama od ovdje ilustriranih vrijedi isto progresivno pravilo povećavanja - 300% x, 400% x, 500% x, 600% x, 700% x, 800% x, 900% x...



minimalna
dimenzija = x
18 x 22 mm



minimalna
dimenzija = x
18 x 22 mm



minimalna
dimenzija = x
18 x 22 mm



150% x



150% x

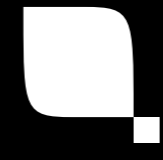

150% x

**PARKS OF
CROATIA**

**PARKS OF
CROATIA**

**PARKS OF
CROATIA**



200% x



200% x

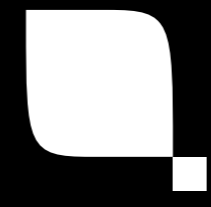

200% x

**PARKS OF
CROATIA**

**PARKS OF
CROATIA**

**PARKS OF
CROATIA**

Minimalni zaštitni prostor

Minimalni zaštitni prostor odnosa znak-logotip je prostor oko znak-logotipa u kojem se ne smiju nalaziti drugi grafički elementi kako se ne bi narušio integritet samog znaka.

Minimalni prostor određen je prema dimenziji 'a' i prikazan je lijevo (točkasti pravokutnik).

Minimalni prostor mijenja se proporcionalno sa dimenzijom samog odnosa znak-logotip.

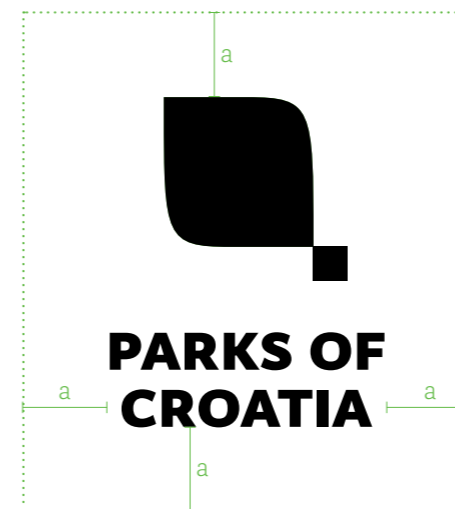
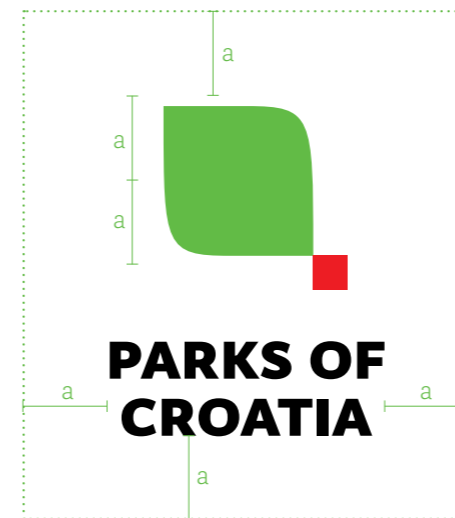
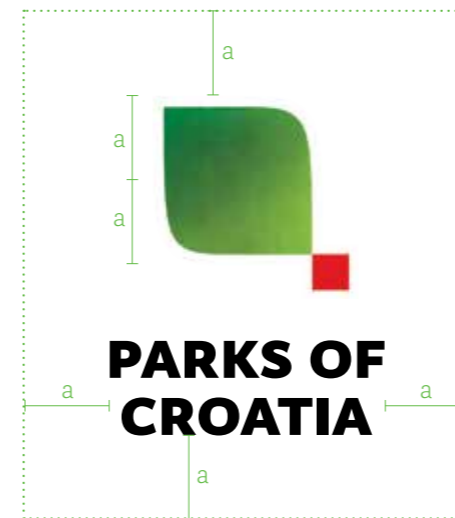

Apliciranje

AKROMATSKE KONTINUIRANE PODLOGE

Akromatske kontinuirane podloge su ravnomjerne podloge sivog spektra.

Znak-logotip se aplicira u negativu na sve akromatske kontinuirane podloge tamnije ili jednake 50% crne.

Znak-logotip se aplicira u pozitivu na sve akromatske kontinuirane podloge svjetlije od 50% crne.



C: 0, M: 0, Y: 0, K: 100

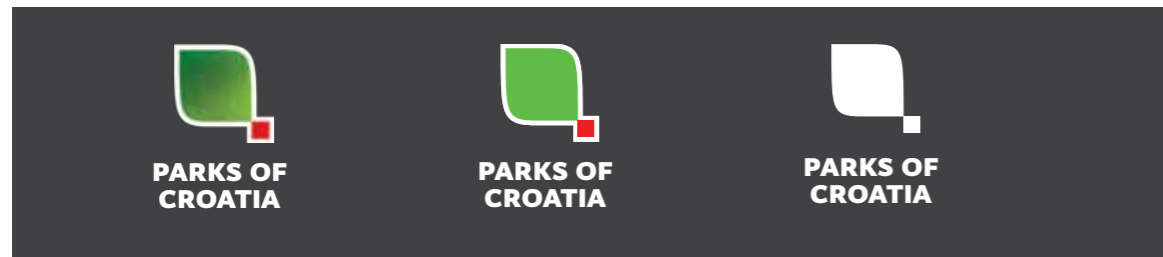

C: 0, M: 0, Y: 0, K: 90



C: 0, M: 0, Y: 0, K: 80



C: 0, M: 0, Y: 0, K: 70



C: 0, M: 0, Y: 0, K: 50



C: 0, M: 0, Y: 0, K: 0



C: 0, M: 0, Y: 0, K: 10



C: 0, M: 0, Y: 0, K: 20



C: 0, M: 0, Y: 0, K: 30



C: 0, M: 0, Y: 0, K: 40

Apliciranje

KROMATSKE KONTINUIRANE PODLOGE

Kromatske kontinuirane podloge su ravnomjerne obojane podloge.

Znak-logotip se aplicira u negativu na sve kromatske kontinuirane podloge tamnije ili jednake 50% crne.

Znak-logotip se aplicira u pozitivu na sve kromatske kontinuirane podloge svjetlije od 50% crne.



C: 100, M: 0, Y: 100, K: 20, grayscale ekvivalent 61%



C: 100, M: 0, Y: 100, K: 20, grayscale ekvivalent 30%



C: 100, M: 60, Y: 0, K: 0, grayscale ekvivalent 65%



C: 85, M: 0, Y: 0, K: 0, grayscale ekvivalent 25%

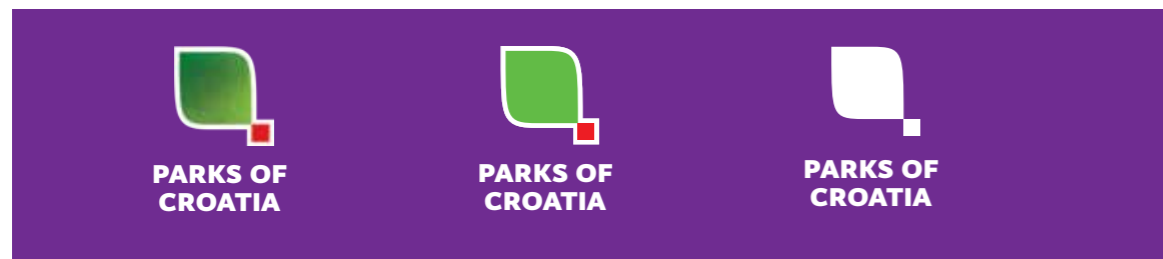

C: 70, M: 100, Y: 0, K: 0, grayscale ekvivalent 80%



C: 30, M: 60, Y: 0, K: 0, grayscale ekvivalent 44%



C: 0, M: 100, Y: 100, K: 5, grayscale ekvivalent 50%



C: 0, M: 50, Y: 100, K: 0, grayscale ekvivalent 40%



C: 0, M: 65, Y: 100, K: 50, grayscale ekvivalent 99%



C: 0, M: 10, Y: 70, K: 10, grayscale ekvivalent 24%

Apliciranje

DISKONTINUIRANE PODLOGE

Diskontinuirana podloga je fotografska ili grafička podloga koja nije jednobojna.

Znak-logotip se aplicira u negativu) na sve diskontinuirane podloge kojima je srednja svjetlina tamnija ili jednaka 50% crne.

Znak-logotip se aplicira u pozitivu na sve diskontinuirane podloge kojima je srednja svjetlina svijetlija od 50% crne.

Treba izbjegavati aplikaciju znaka-logotipa na diskontinuiranu podlogu koja je toliko heterogena da logotip (i pozitiv i negativ verzija) postaje nečitak.



Zabrane

ZABRANJENE APLIKACIJE I MANIPULACIJE

Odnos znak-logotip se nikada ne smije deformirati (sužavati, izduživati, skraćivati, rotirati...). Odnos znak-logotip strogo je propisan, te se svako njegovo narušavanje smatra deformacijom.

Dozvoljena apliciranja znaka-logotipa na razne pozadine ovise o njegovoj čitkosti i nenarušavanju vizualne komunikativnosti.

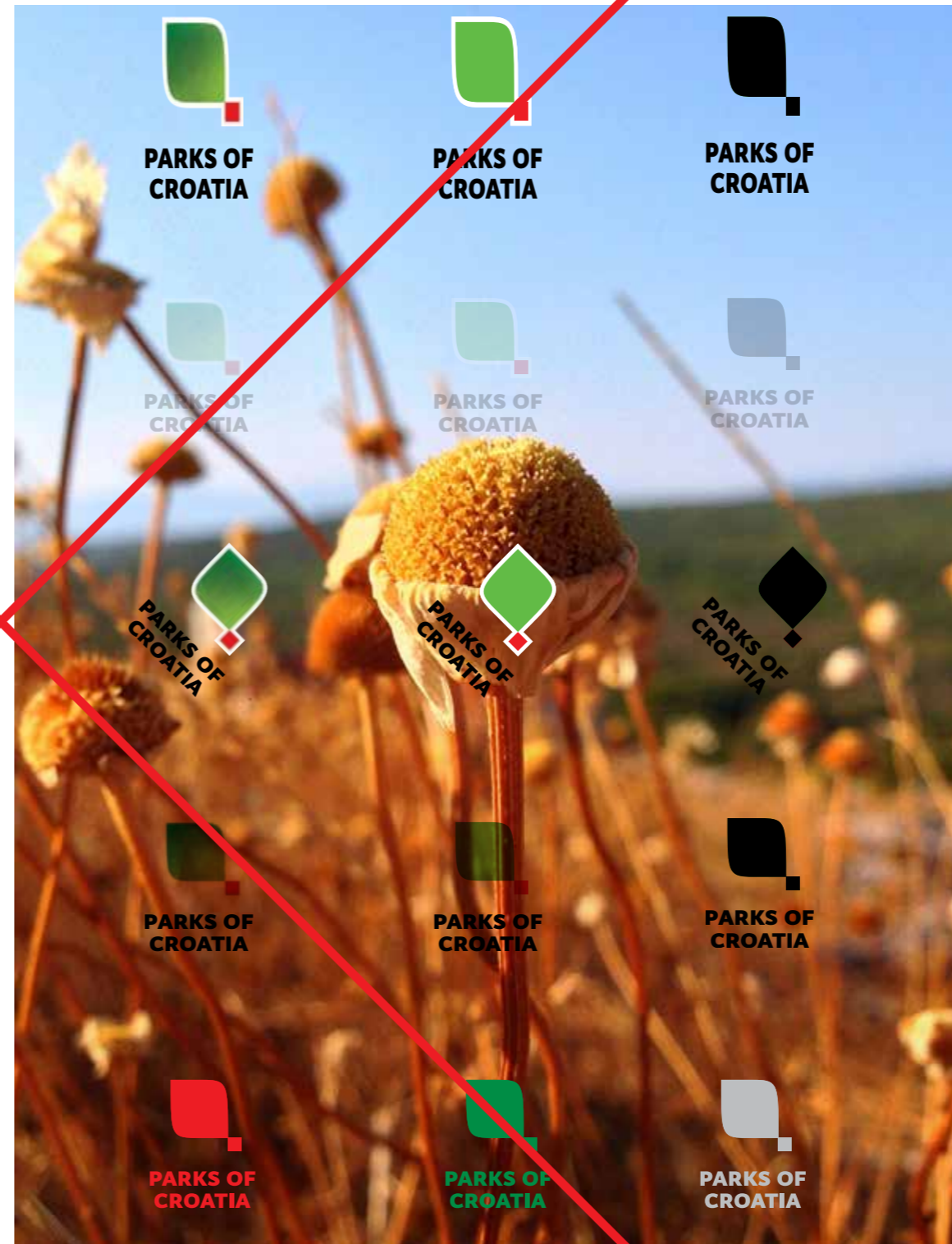
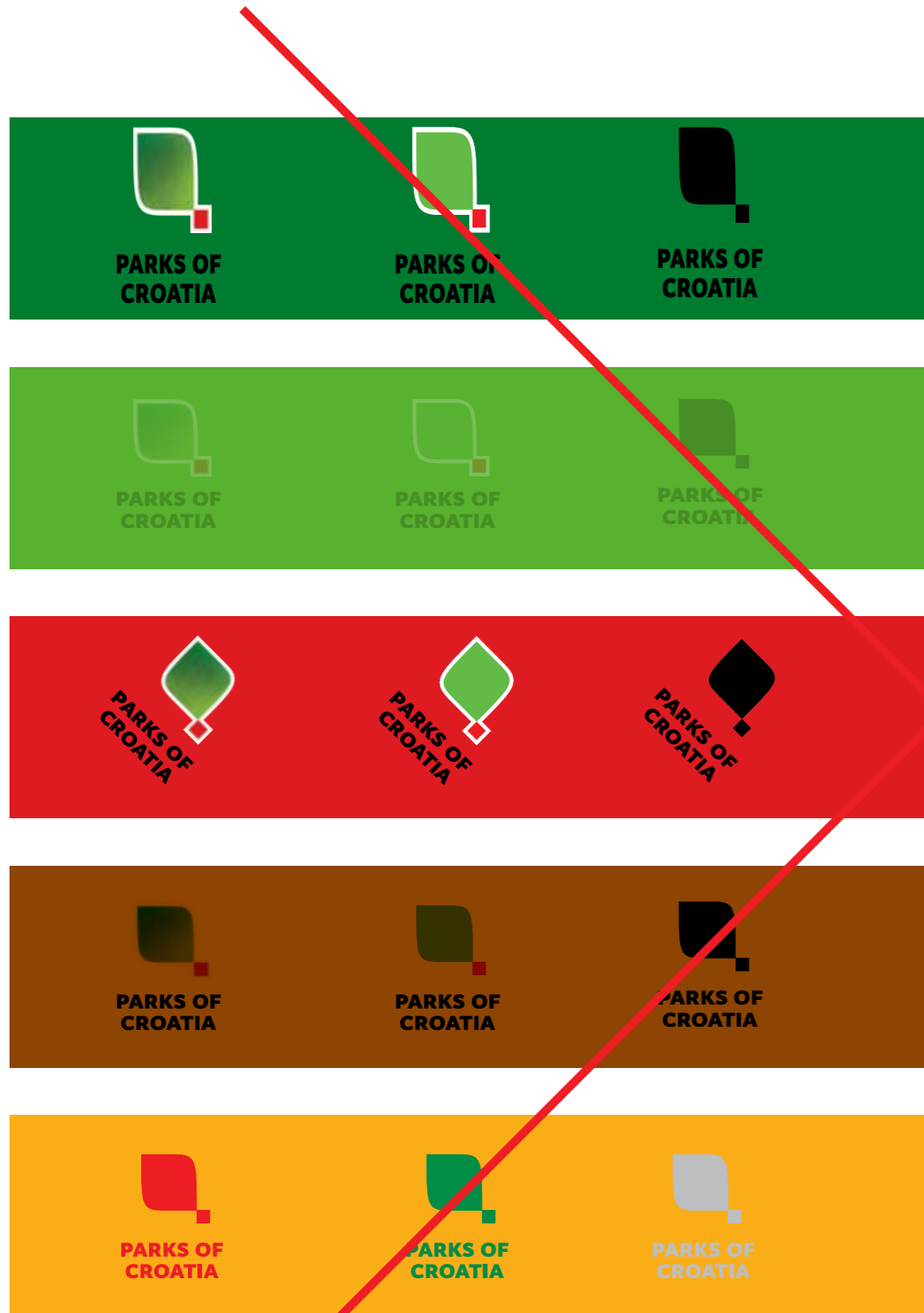



↑
AKVAREL ZNAK-LOGOTIP VERTIKALNI NEGATIV



↑
KOLOR ZNAK-LOGOTIP VERTIKALNI NEGATIV



↑
CRNO-BIJELI ZNAK-LOGOTIP VERTIKALNI NEGATIV



↑
AKVAREL ZNAK-LOGOTIP VERTIKALNI POZITIV



↑
KOLOR ZNAK-LOGOTIP VERTIKALNI POZITIV



↑
CRNO-BIJELI ZNAK-LOGOTIP VERTIKALNI POZITIV

Vertikalni odnosi

NEGATIV

AKVAREL ZNAK-LOGOTIP VERTIKALNI

'Akvarel znak-logotip vertikalni' primarni je odnos znak-logotip i preporuča se njegovo korištenje gdje god tehnika reprodukcije i sam dizajn to dopuštaju.

KOLOR ZNAK-LOGOTIP VERTIKALNI

'Kolor znak-logotip vertikalni' sekundarni je odnos znak-logotip. Upotrebljava se kada tehnika reprodukcije ne dopušta korištenje 'akvarel znak-logotip horizontalni'. (npr. sitotisak, oslikavanje, tampon tisak, katiranje, štik itd.)

CRNO-BIJELI ZNAK-LOGOTIP VERTIKALNI

'Crno-bijeli znak-logotip vertikalni' tercijarni je odnos znak-logotip. Upotrebljava se isključivo u situacijama kada je nemoguća kolor reprodukcija ili dizajn zahtjeva monokromatski znak-logotip. (npr. gravura, katiranje itd.)

POZITIV

AKVAREL ZNAK-LOGOTIP VERTIKALNI

'Akvarel znak-logotip vertikalni' primarni je odnos znak-logotip i preporuča se njegovo korištenje gdje god tehnika reprodukcije i sam dizajn to dopuštaju.

KOLOR ZNAK-LOGOTIP VERTIKALNI

'Kolor znak-logotip vertikalni' sekundarni je odnos znak-logotip. Upotrebljava se kada tehnika reprodukcije ne dopušta korištenje 'akvarel znak-logotip horizontalni'. (npr. sitotisak, oslikavanje, tampon tisak, katiranje, štik itd.)

CRNO-BIJELI ZNAK-LOGOTIP VERTIKALNI

'Crno-bijeli znak-logotip vertikalni' tercijarni je odnos znak-logotip. Upotrebljava se isključivo u situacijama kada je nemoguća kolor reprodukcija ili dizajn zahtjeva monokromatski znak-logotip. (npr. gravura, žig itd.)

Dimenzije

Dimenzije odnosa znak-logotip određuju se kako bi se stvorio kontinuitet veličina.

POZITIV

Minimalna veličina vertikalnog odnosa znak-logotip je 19 × 23 mm. Vertikalni znak-logotip se ne smije upotrebljavati manji od te dimenzije.

Za znak-logotip koji se upotrebljava u većim dimenzijama od ovdje ilustriranih vrijedi isto progresivno pravilo povećavanja - 300% x, 400% x, 500% x, 600% x, 700% x, 800% x, 900% x...

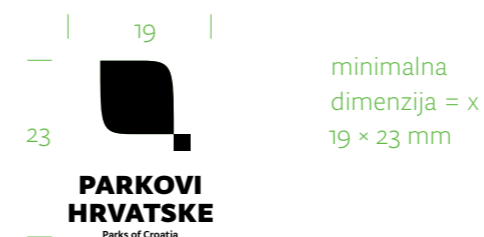

Dimenzije

Dimenzije odnosa znak-logotip određuju se kako bi se stvorio kontinuitet veličina.

NEGATIV

Minimalna veličina vertikalnog odnosa znak-logotip je 19 × 24 mm. Vertikalni znak-logotip se ne smije upotrebljavati manji od te dimenzije.

Za znak-logotip koji se upotrebljava u većim dimenzijama od ovdje ilustriranih vrijedi isto progresivno pravilo povećavanja - 300% x, 400% x, 500% x, 600% x, 700% x, 800% x, 900% x...



minimalna dimenzija = x
19 × 24 mm



minimalna dimenzija = x
19 × 24 mm



minimalna dimenzija = x
19 × 24 mm



150% x

PARKOVI HRVATSKE
Parks of Croatia



150% x

PARKOVI HRVATSKE
Parks of Croatia

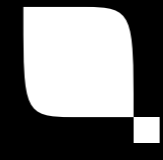

150% x

PARKOVI HRVATSKE
Parks of Croatia



200% x

PARKOVI HRVATSKE
Parks of Croatia



200% x

PARKOVI HRVATSKE
Parks of Croatia



200% x

PARKOVI HRVATSKE
Parks of Croatia

Minimalni zaštitni prostor

Minimalni zaštitni prostor odnosa znak-logotip je prostor oko znak-logotipa u kojem se ne smiju nalaziti drugi grafički elementi kako se ne bi narušio integritet samog znaka.

Minimalni prostor određen je prema dimenziji 'a' i prikazan je lijevo (točkasti pravokutnik).

Minimalni prostor mijenja se proporcionalno sa dimenzijom samog odnosa znak-logotip.



Apliciranje

AKROMATSKE KONTINUIRANE PODLOGE

Akromatske kontinuirane podloge su ravnomjerne podloge sivog spektra.

Znak-logotip se aplicira u negativu na sve akromatske kontinuirane podloge tamnije ili jednake 50% crne.

Znak-logotip se aplicira u pozitivu na sve akromatske kontinuirane podloge svijetlije od 50% crne.



C: 0, M: 0, Y: 0, K: 100

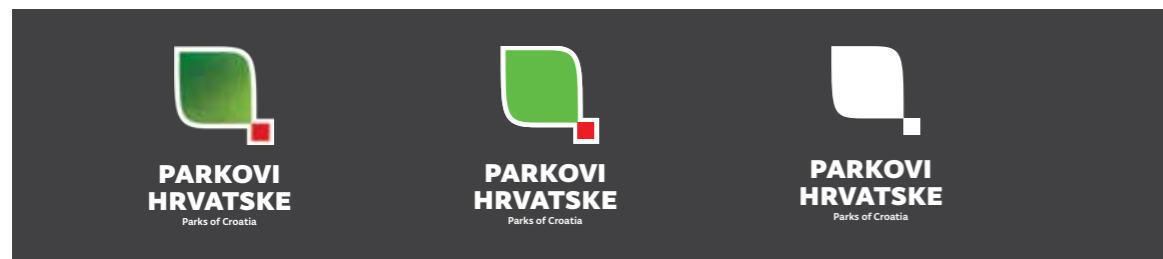

C: 0, M: 0, Y: 0, K: 90



C: 0, M: 0, Y: 0, K: 80



C: 0, M: 0, Y: 0, K: 70



C: 0, M: 0, Y: 0, K: 50



C: 0, M: 0, Y: 0, K: 0



C: 0, M: 0, Y: 0, K: 10



C: 0, M: 0, Y: 0, K: 20

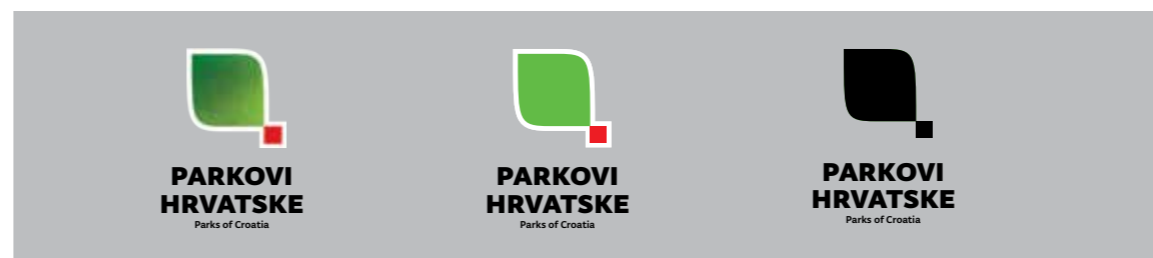

C: 0, M: 0, Y: 0, K: 30



C: 0, M: 0, Y: 0, K: 40

Apliciranje

KROMATSKE KONTINUIRANE PODLOGE

Kromatske kontinuirane podloge su ravnomjerne obojane podloge.

Znak-logotip se aplicira u negativu na sve kromatske kontinuirane podloge tamnije ili jednake 50% crne.

Znak-logotip se aplicira u pozitivu na sve kromatske kontinuirane podloge svijetlije od 50% crne.



C: 100, M: 0, Y: 100, K: 20, grayscale ekvivalent 61%



C: 100, M: 0, Y: 100, K: 20, grayscale ekvivalent 30%



C: 100, M: 60, Y: 0, K: 0, grayscale ekvivalent 65%

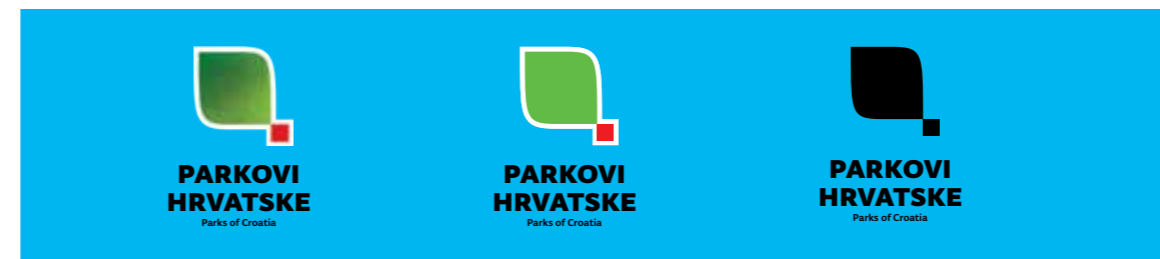

C: 85, M: 0, Y: 0, K: 0, grayscale ekvivalent 25%

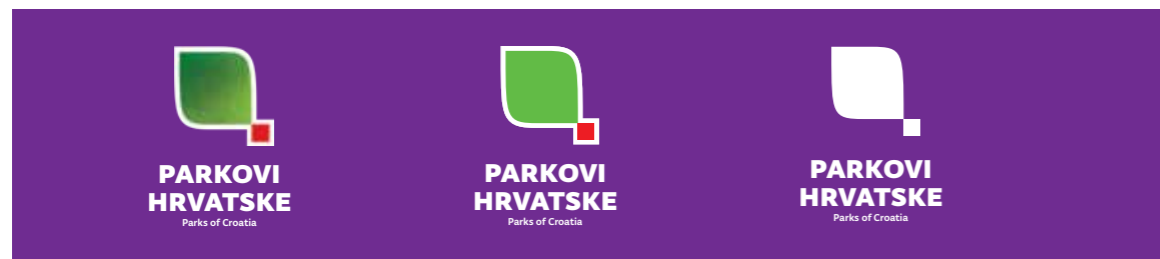

C: 70, M: 100, Y: 0, K: 0, grayscale ekvivalent 80%



C: 30, M: 60, Y: 0, K: 0, grayscale ekvivalent 44%



C: 0, M: 100, Y: 100, K: 5, grayscale ekvivalent 50%

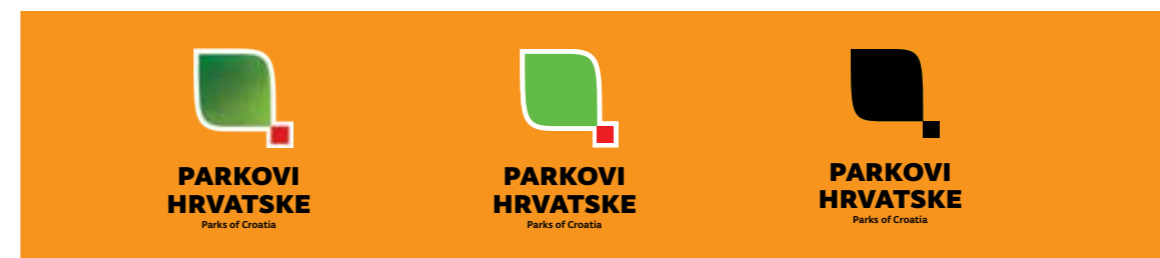

C: 0, M: 50, Y: 100, K: 0, grayscale ekvivalent 40%



C: 0, M: 65, Y: 100, K: 50, grayscale ekvivalent 99%

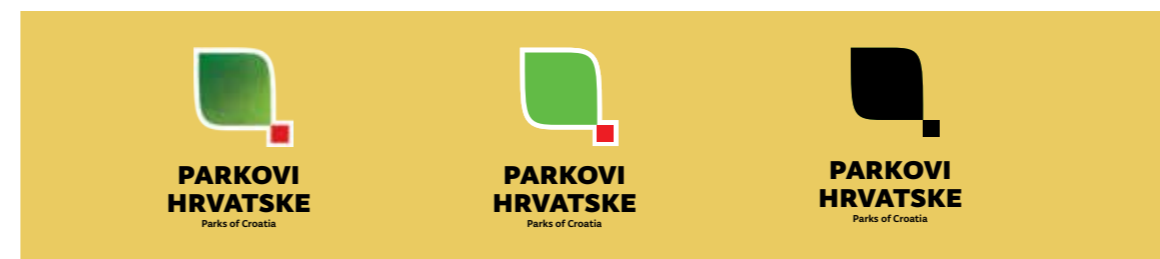

C: 0, M: 10, Y: 70, K: 10, grayscale ekvivalent 24%

Apliciranje

DISKONTINUIRANE PODLOGE

Diskontinuirana podloga je fotografska ili grafička podloga koja nije jednobojna.

Znak-logotip se aplicira u negativu) na sve diskontinuirane podloge kojima je srednja svjetlina tamnija ili jednaka 50% crne.

Znak-logotip se aplicira u pozitivu na sve diskontinuirane podloge kojima je srednja svjetlina svijetlija od 50% crne.

Treba izbjegavati aplikaciju znaka-logotipa na diskontinuiranu podlogu koja je toliko heterogena da logotip (i pozitiv i negativ verzija) postaje nečitak.



Zabrane

ZABRANJENE APLIKACIJE I MANIPULACIJE

Odnos znak-logotip se nikada ne smije deformirati (sužavati, izduživati, skraćivati, rotirati...). Odnos znak-logotip strogo je propisan, te se svako njegovo narušavanje smatra deformacijom.

Dozvoljena apliciranja znaka-logotipa na razne pozadine ovise o njegovoj čitkosti i nenarušavanju vizualne komunikativnosti.



Aa Bb

Typonine Sans Light

Aa Bb

Typonine Sans Normal

Aa Bb

Typonine Sans Text

Aa Bb

Typonine Sans Light Italic

Aa Bb

Typonine Sans Normal Italic

Aa Bb

Typonine Sans Text Italic

Aa Bb

Typonine Sans Medium

Aa Bb

Typonine Sans Bold

Aa Bb

Typonine Sans Medium Italic

Aa Bb

Typonine Sans Bold Italic

Tipografija jedinstvenog vizualnog identiteta

Tipografija je jedan od osnovnih elemenata vizualnog identiteta (uz znak, logotip i boju).

Typonine Sans preporučena je tipografija ovog vizualnog identiteta. Typonine ima 10 rezova i zadovoljava gotovo sve potrebe.

Boja jedinственog vizualnog identiteta

Boja je jedan od osnovnih elemenata vizualnog identiteta (uz znak, logotip i tipografiju).

Radi jačanja prepoznatljivosti vizualnog identiteta preporuča se upotreba identitetskih boja gdje god je moguće.



PANTONE 360
RAL 6018
C: 65%, M: 0%, Y: 100%, K: 0%
R: 97, G: 194, B: 80
HTML: 61C250



PANTONE 348
RAL 6029
C: 100%, M: 0%, Y: 100%, K: 20%
R: 0, G: 133, B: 66
HTML: 009B48



PANTONE 186
RAL 3020
C: 0%, M: 100%, Y: 100%, K: 0%
R: 224, G: 0, B: 52
HTML: E00034

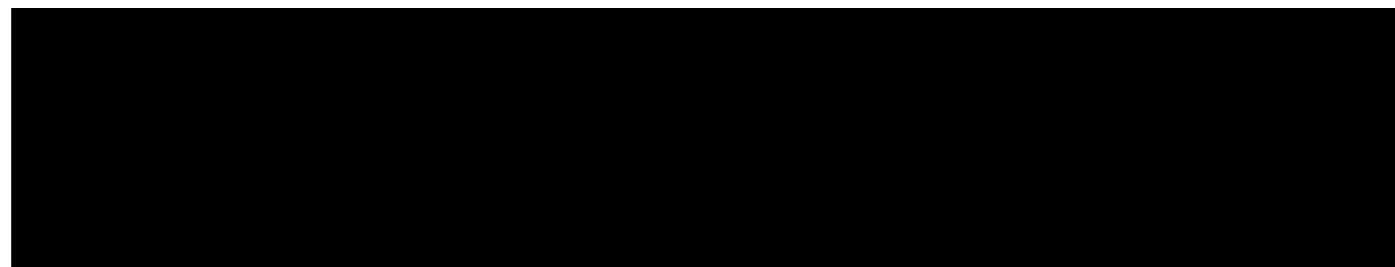

PANTONE BLACK
RAL 9011
C: 0%, M: 0%, Y: 0%, K: 100%
R: 0, G: 0, B: 0
HTML: 000000

Odnosi znaka zaštite prirode i znaka pojedine javne ustanove

Ovdje su definirani odnosi znaka zaštite prirode sa znakom pojedine javne ustanove. Sustav se odnosi na materijale na kojima se na istoj stranici, površini pojavljuju oba znaka (npr. plakat, web stranica, letak, ulaznica itd...). Na materijalima koji, po svojoj logici, zahtjevaju drugačiji tretman znakova (npr. majice, ikona mobilne aplikacije, šalica...) ne mora se držati ovog sustava.

Osnovna logika kojeg drži ovaj sustav je da se znakovi javnih ustanova i znak zaštite prirode koriste u istoj veličini i istom obliku (akvarel/akvarel, horizontalni odnos/horizontalni odnos) te da je znak javne ustanove na primarnoj poziciji, a znak zaštite prirode u sekundarnoj poziciji. Primarna i sekundarna pozicija određena je s lijeva na desno i odozgo prema dolje. U horizontalnom odnosu znakova lijeva pozicija je primarna, a u vertikalnom odnosu gornja.

Za potrebe ove knjige standarda ilustracije su izvedene sa znakom parka prirode Medvednice, ali svaka javna ustanova koristi svoj znak na isti način kako je ilustrirano i opisano knjigom standarda.

Horizontalan odnos

Znak javne ustanove i znak zaštite prirode mogu se pozicionirati tako da su poravnati verikalno ili horizontalno.

U situaciji kada su poravnati horizontalno (kao u ilustraciji lijevo) postoje dva pravila:

1. uvijek koristiti iste tipove znaka (npr. oba akvarel, pozitivna ili oba kolor negativ)
2. odnosi veličina znakova moraju biti ujednačeni kao na ilustraciji lijevo.



Horizontalan odnos

Znak-logotip javne ustanove i znak zaštite prirode i logotip Parkovi Hrvatske mogu se pozicionirati tako da su poravnati verikalno ili horizontalno.

U situaciji kada su poravnati horizontalno (kao u ilustraciji lijevo) postoje dva pravila:

1. uvijek koristiti iste tipove znak-logotip (npr. oba akvarel, horizontalna ili oba kolor negativ horizontalna)
2. odnosi veličina znak-logotipa moraju biti ujednačeni kao na ilustraciji lijevo.



Horizontalan odnos

Znak-logotip javne ustanove i znak zaštite prirode i logotip Parkovi Hrvatske mogu se pozicionirati tako da su poravnati verikalno ili horizontalno.

U situaciji kada su poravnati horizontalno (kao u ilustraciji lijevo) postoje dva pravila:

1. uvijek koristiti iste tipove znak-logotip (npr. oba akvarel, vertikalna ili oba kolor negativ vertikalna)
2. odnosi veličina znak-logotipa moraju biti ujednačeni kao na ilustraciji lijevo.



MEDVEDNICA
Park prirode • Nature Park

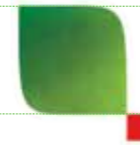

PARKOVI HRVATSKE
Parks of Croatia



MEDVEDNICA
Park prirode • Nature Park



PARKOVI HRVATSKE
Parks of Croatia



MEDVEDNICA
Park prirode • Nature Park



PARKOVI HRVATSKE
Parks of Croatia



MEDVEDNICA
Park prirode • Nature Park



PARKOVI HRVATSKE
Parks of Croatia



MEDVEDNICA
Park prirode • Nature Park



PARKOVI HRVATSKE
Parks of Croatia



MEDVEDNICA
Park prirode • Nature Park



PARKOVI HRVATSKE
Parks of Croatia

Vertikalan odnos

Znak javne ustanove i znak zaštite prirode mogu se pozicionirati tako da su poravnati verikalno ili horizontalno.

U situaciji kada su poravnati vertikalno (kao u ilustraciji lijevo) postoje dva pravila:

1. uvijek koristiti iste tipove znakova (npr. oba akvarel ili oba kolor negativ)
2. odnosi veličina znakova moraju biti ujednačeni kao na ilustraciji lijevo.

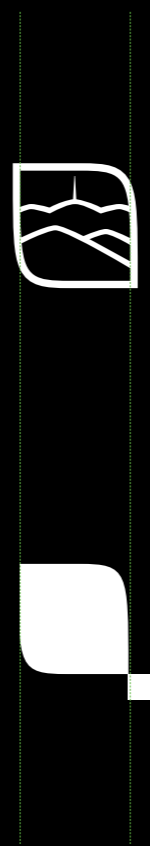
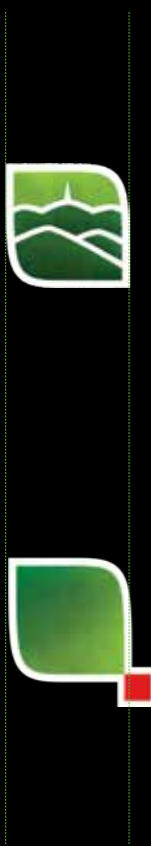

Vertikalan odnos

Znak-logotip javne ustanove i znak zaštite prirode i logotip Parkovi Hrvatske mogu se pozicionirati tako da su poravnati verikalno ili horizontalno.

U situaciji kada su poravnati vertikalno (kao u ilustraciji lijevo) postoje dva pravila:

1. uvijek koristiti iste tipove znak-logotip (npr. oba akvarel, horizontalna ili oba kolor negativ horizontalna)
2. odnosi veličina znak-logotipa moraju biti ujednačeni kao na ilustraciji lijevo.



Vertikalan odnos

Znak-logotip javne ustanove i znak zaštite prirode i logotip Parkovi Hrvatske mogu se pozicionirati tako da su poravnati verikalno ili horizontalno.

U situaciji kada su poravnati vertikalno (kao u ilustraciji lijevo) postoje dva pravila:

1. uvijek koristiti iste tipove znak-logotip (npr. oba akvarel, vertikalna ili oba kolor negativ vertikalna)
2. odnosi veličina znak-logotipa moraju biti ujednačeni kao na ilustraciji lijevo.

